

Slipring Assemblies

SK5, SK6, SK12

Inhalt	Seite
Safety instructions	4
1 Scope of supply (SK5, SK6)	5
2 Range of application	6
3 Slipping head SK6, SK12	6
3.1 Design and function	6
4 Mounting (see also safety notes)	6
4.1 Mounting with mounting plate	7
4.2 Mounting without mounting plate	8
5 Connection of measurements leads	8
5.1 Hints for measurements	9
5.2 Mass or earth connection	9
6 Maintenance	10
6.1 Exchange of brushes	10
7 Technical Data	11
8 Dimensions	12
9 Slipping assembly SK5	14
9.1 Design and function	14
9.1.1 Slipping body SK5	14
9.1.2 Brush holder SK5/ZB	14
10 Mounting (see safety notes)	15
10.1 Mounting of slipping body SK5 with brush holder SK5/ZB	15
11 Connection of measurement leads	16
11.1 Hints for measurements	17
11.2 Mass or earth connection	17
12 Maintenance	18
13 Technical Data	19
13.1 Electrical values	19
13.2 Mechanical values	19
14 Dimensions	20
15 Scope of supply (SK5)	21

Safety instructions

In accordance with accident prevention rules of the professional associations the user of the slipping assemblies SK5, SK6, and SK12 has to provide, after-fitting of the assemblies, a cover as follows:

- covers or shields must not rotate.
- covers and shields shall avoid any possible shear action, and shall be safe even if parts become loose.
- covers and shields shall be far enough from rotating parts, or shall prevent touching them with fingers.
- covers and shields shall also be mounted if rotating parts of slipping assemblies are operated outside the access room or working space of persons.

Any deviation from above rules is only permitted if the machine parts are sufficiently protected by the design of the machine or other safety measures already fitted to the machine.

1 Scope of supply (SK5, SK6)

- 1 piece slipping head SK6 or SK12 resp.
- 1 piece mounting bracket
- 2 pieces screws M 3 x 6 mm
- 1 piece Allen key 3 mm
- 1 piece Allen key 4 mm

2 Range of application

The slipring assemblies SK5, SK6, and SK12 transmit measurement signals from rotating electrical transducers to stationary measurement systems. For that purpose the slipring heads SK6 and SK12 can be connected to shaft ends whereas the slipring body SK5 must be fitted to shafts. The wide range of application permits to transmit measured values from inductive and resistive transducers, strain gauge applications, thermometers and thermocouples as well as other transducers. By selecting best suited materials a very small wear as well as high transmission quality are achieved. There is only small thermo voltage generated between sliprings and brushes, and the contact resistance between sliprings and brushes is only very small as well as its change with speed of rotation, temperature, and current.

There are cases where the slipring heads SK6 and SK12 cannot be fitted. However, there is the slipring body SK5 with the appropriate set of brushes (2 x 5 brushes). These are integral elements requiring less space than the slipring heads SK6 and SK12.

3 Slipring head SK6, SK12

3.1 Design and function

The main parts of the slipring head are the stator with two brush arrays at opposite sides and a rotor with 6 or 12 hard silver slip rings. The brushes can be engaged even with the shaft running or lifted afterwards by just turning a ring. Worn brushes can be easily replaced. For mounting purposes the apparatus can be separated into stator and rotor part. Then the rotor part can be fixed either directly or via the mounting plate to the front end of a shaft.

The slipring heads SK6 and SK12 are basically alike, the only difference being their number of sliprings contained.

4 Mounting (see also safety notes)

The slipring assemblies SK6 and SK12 have to be fitted, that rough dirt, dust, humidity, oil, solvents and their gases can not reach the slipring or get into the case. They could influence the slipring transmission or e.g. reduce the resistance to ground of a connected measuring point.

4.1 Mounting with mounting plate (see Fig. 8.3)

1. Turn mark on ring (15) to position  to the stop: brushes are lifted.
2. Loosen locking screw (9) at the front of slipring head.
3. Carefully pull away stator from rotor (14).
4. Unscrew the four Allan screws (2) at the inner front of the rotor and remove mounting plate (1).
5. If the rotor is fixed by the mounting plate suitable through holes for M5 or M6 screws have to be bored with proper countersinking. Note: Heads of the fixing screws shall be completely sunk in plate.
6. Fix the mounting plate properly centered and smoothly running to the front of the shaft. If a hollow shaft is used with the connection wires within the shaft these should be brought out through the four slots (12) of the mounting plate (1).
7. Connect rotor again with mounting plate with the screws, Slide on stator with brushes lifted and fasten locking screw properly.
8. Prevent rotation of the stator with the mounting bracket (11). This must not be rigidly fixed at some support because the slipring might be damaged if the shaft beats. Le. performs slight radial or axial move, ents. One either allows the mounting bracket to press against a stop or fixes it with some flexible member. For fastening of the mounting grid only screws M 3 x 6 shall be used, otherwise the inner parts of the slipring head might be damaged. The air vents beside the mounting bracket shall point in that direction where the least dirt comes from i.e. in most cases downward.

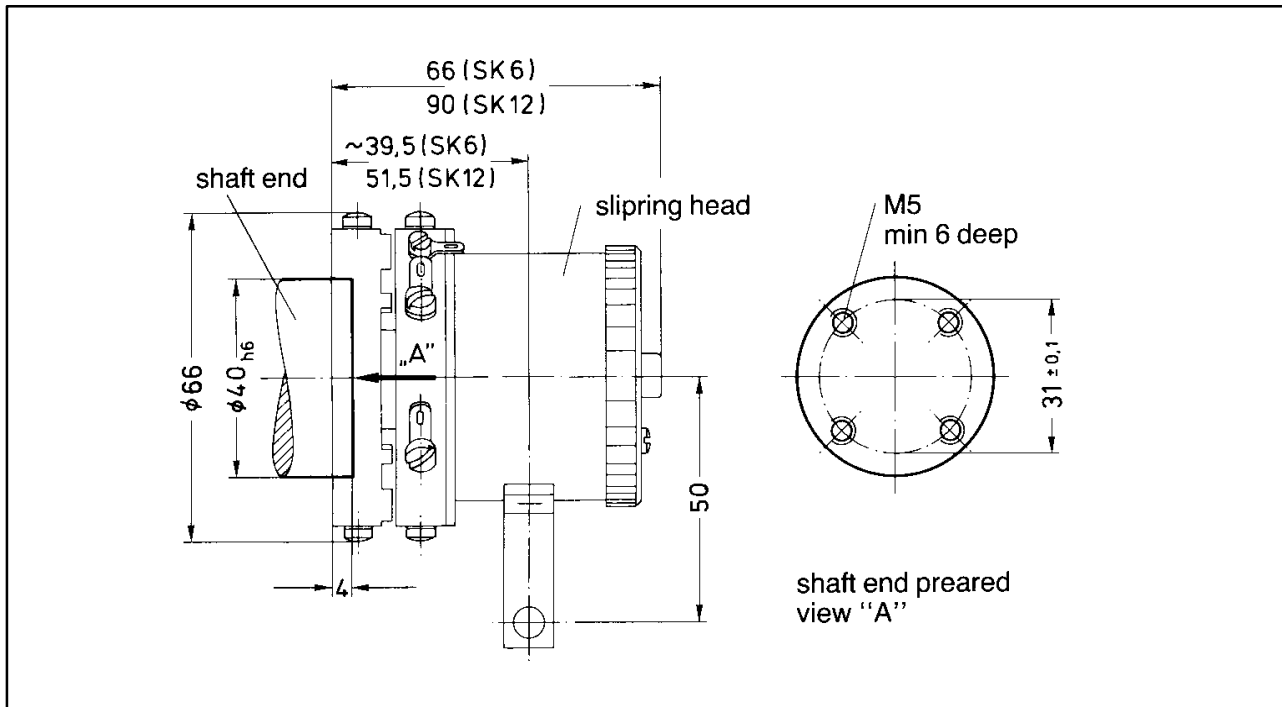

Fig. 4.1: Mounting without mounting plate

4.2 Mounting without mounting plate

It is quite feasible to mount the slipring heads SK6 and SK12 also without the mounting plate. Make sure that the seating is perfectly centered and running smoothly. The optimum mounting is obtained if the shaft end is machined to $\phi 40_{h6}$. Points 1 ... 4 and 8 of chapter 4.1 are applicable. Fig. 4.1 shows a mounting example which will, however, not permit leading the cable inside a hollow shaft.

5 Connection of measurements leads

The stator is equipped with 6 or 12 soldertags, corresponding to the number of sliprings, for the connection of cables which are numbered 1 to 6 or 1 to 12. The rotor has the same number of connections. The solder tags number 1 are additionally marked with a red dot. These shall be side by side when the cables are connected.

5.1 Hints for measurements

In the case of strain gauge measurements it is advisable to use the full bridge circuit since in that case there will be the least influence from the slipping transmission, compared to half or quarter bridge configurations. For very precise measurements the 700 Ω strain gauge full bridge is preferred, however, even with 350 Ω or 120 Ω full, half, or quarter bridges the errors will be comparatively small.

5.2 Mass or earth connection

In order to avoid errors or disturbances from static charges the rotor shall be properly earthed. For that purpose one connects a free slipping and the corresponding brush with the machine earth. Additionally the stator housing earth (soldertag between connections 3 and 4 and 6 and 7 resp.) shall be connected with machine earth.

If the operating voltage zero (\perp) of the amplifier shall also be connected to this earthing point one should do this by soldering the cable screen to the earthed solder tag of the stator. No other earth connection shall be used in order to avoid earth loops (see fig. 5.1).



Abb. 5.1: Mounting without mounting plate

6 Maintenance

The brushes shall only be engaged for the actual measurement. This will greatly reduce the wear. If dirt is accumulating on the brushes or on sliprings it is recommended to clean them with a cleaning agent. If the brushes are worn out these must be replaced.

Due to the very long service life of the brushes these only need replacing after long periods of operation. If service speeds are mostly below the specified maximum speed of rotation, the average service life of the brushes will be 8×10^8 revolutions.

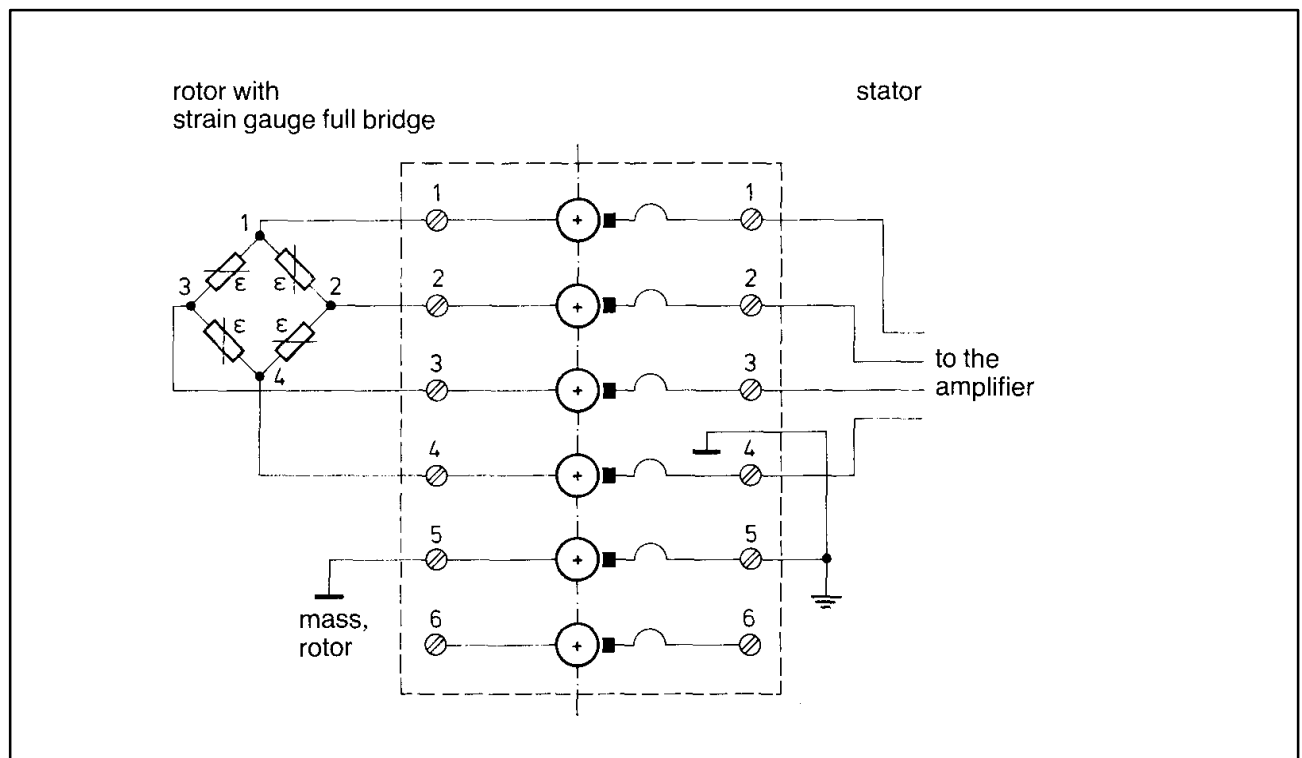
6.1 Exchange of brushes (see Fig. 8.3)

When ordering replacement brushes please quote Stock–No. 3–3098.0028 and type of slipring head. Replacing of brushes should be carried out as follows:

1. Separate stator as described under 4.1: 1 ... 3.
2. Loosen the three screws (16) on the name plate (8).
3. Take away front plate (7), ring (15), and case (3). Bolts (5) above and below brush group must be unscrewed.
4. After removing the two bolts lift brush–arms (4) by using a soft pin. The graphite brushes can be easily replaced.
5. Before reassembling sliprings should be cleaned by using a soft cloth with benzine or trichloro–ethylene.

If the customer cannot exchange the brushes HBM offer servicing of the unit including exchange of brushes at the Darmstadt factory.

7 Technical Data

Type		SK5	SK12
Number of sliprings		6	12
Resistance between slipring and brush	mΩ	< 40	
Fluctuation of the resistance	mΩ	< 2	
Termo-electric voltage measured between tow brushes when the sliprings are short-circuited (after runing until warm)	μV	< 10	
Voltage limit	V	60	
Current limit	A	2	
Permitted speed for continuous duty	min ⁻¹	6000	
Permissible vibration Frequency range	Hz	10..55	
Duration	h	1.5	
Acceleration	m/s ²	50	
Mechanical shocktest ¹⁾ Number of shocks		1000	
Duration	ms	3	
Acceleration	m/s ²	150	
Moment of massinertia, I_x (axial)	gm ²	0.082	0.0875
Nominal temperature range	°C	- 10...+ 60 ²⁾	
Service temperature range	°C	- 10...+ 70 ³⁾	
Storage temperature range	°C	- 50...+ 90	
Weight approx.	kg	0.55	0.65

1) After the shocktest, no change of technical dala has been noted

2) Permissible ambient temperature = $(60 - 0.002 - n)$ °C; n in min⁻¹

3) Permissible ambient temperature = $(70 - 0.002 n)$ °C; n in min⁻¹

8 Dimensions

Fig. 8.1: Slipping head SK6/SK12

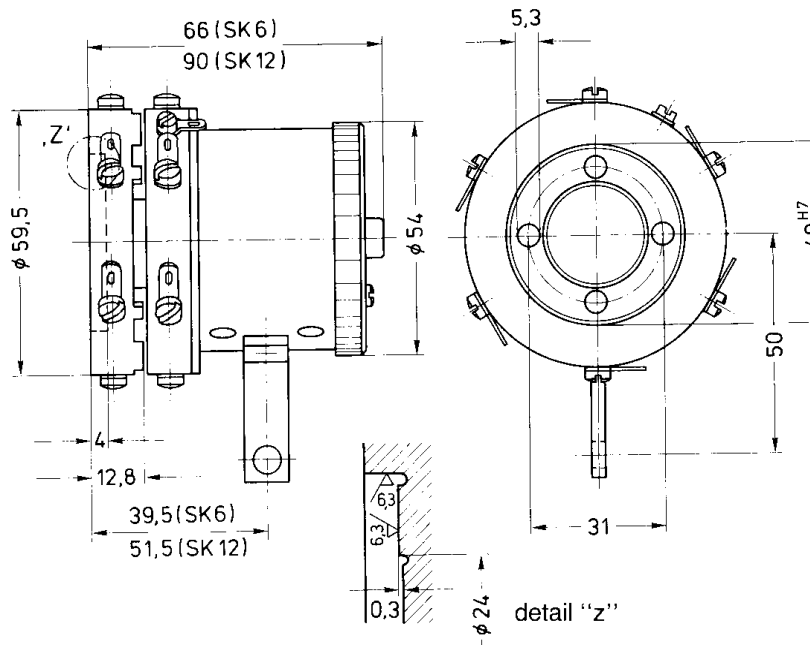
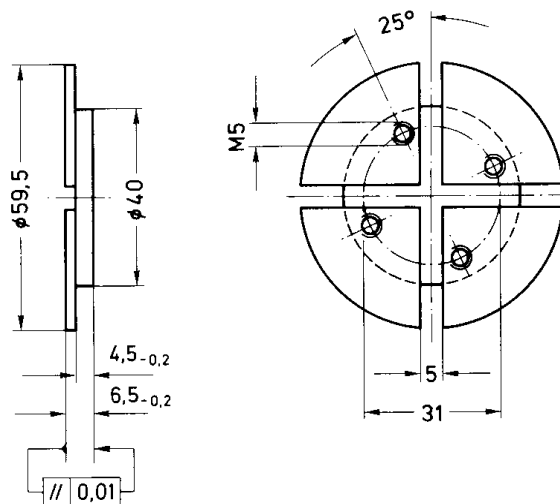

Fig. 8.2: Mounting plate



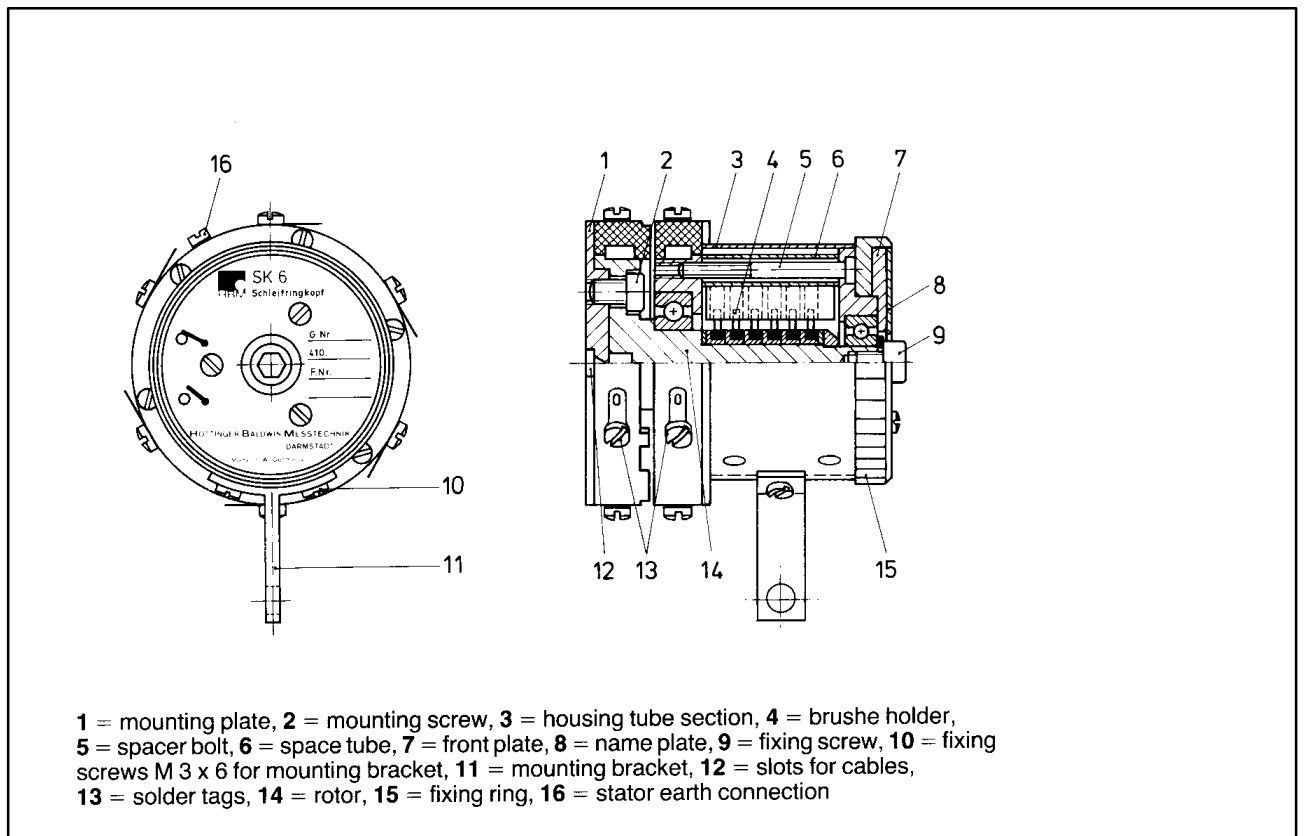

Fig. 8.3: Mechanical outline (slipring head SK6)

9 Slipping assembly SK5

9.1 Design and function

9.1.1 Slipping body SK5

The slipping body comprises a hollow cylinder with five hard silver slirings. It is supplied suitable for various shaft diameters with internal diameters 40^{M6} , 50^{M6} , 55^{M6} , 80^{N6} , and 95^{N6} . Thus the slipping bodies can be fitted to shaft ends with the corresponding fit h6 as a light interference fit. This connection can additionally be secured with an Allen screw M4.

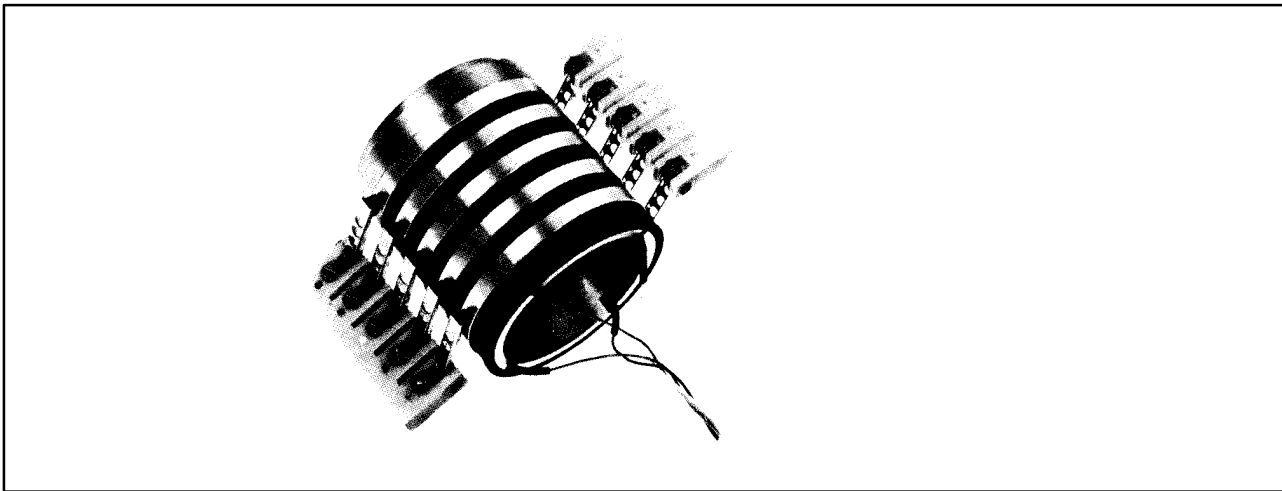

Fig. 9.1: Slipping assembly SK5

9.1.2 Brush holder SK5/ZB

Two brush holders SK5/ZB with five brushes each complete the slipping body to form the assembly. The five brushes are arranged for signal transmission on the holder. They can move about a common bolt and springs will provide the necessary mechanical pressure. Two holes with M3 thread are for the mounting of the brush holder. Thus the fixing can be designed according to the requirements. The optimum arrangement of slipping body and holder is shown in Fig. 10.1.

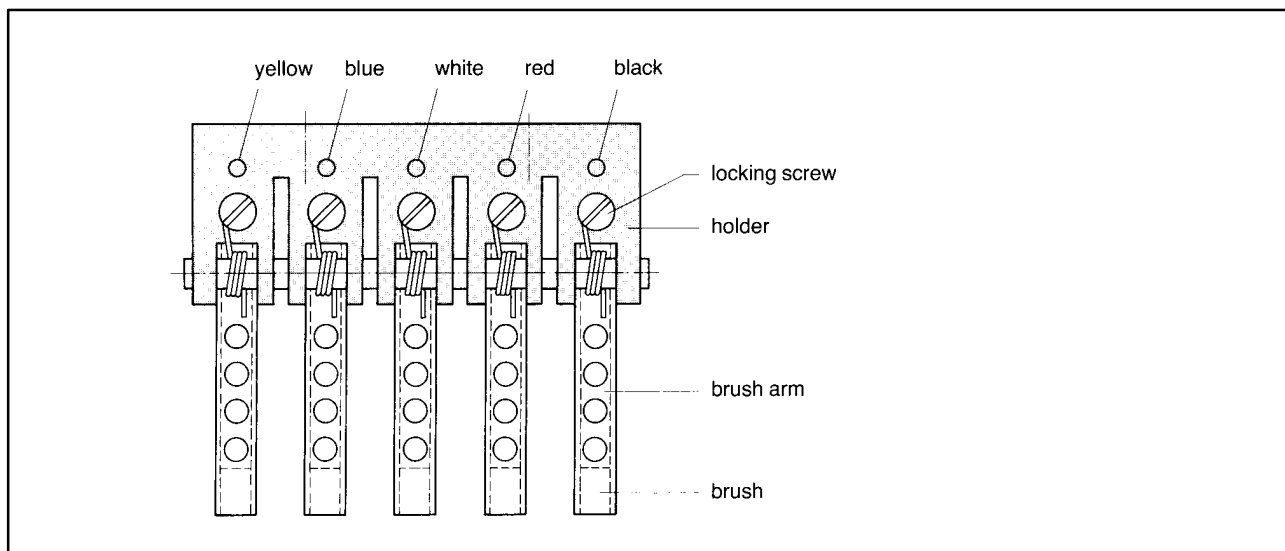

Fig. 9.2: Brush holder SK5/ZB

10 Mounting (see safety notes)

10.1 Mounting of slipping body SK5 with brush holder SK5/ZB

1. The shaft end intended for the slipping body shall be machined to dimension as required for the inner diameter of the slipping, tolerance h6, for a length E (see chapter 14. Dimensions).
2. The slipping body is mounted with a light interference fit to the shaft, cables showing in the direction of the transducer connections.
3. Fasten Allen screw to secure the connection.
4. The brush holders shall be arranged at opposite sides of the shaft (see fig. 10.1). This is precondition for a safe signal transmission. The brush holders shall be mounted in such a way that the brush underneath the black clamping screw is associated with the first slipping next to the cable outlet. The clamp connections marked with colours on the brush holder will then be in the same sequence as cable core colours of the slipping body.
5. Align the brush holders in such a manner that all brushes have full contact with the slippings.

Note:

- When fitting the slipping body make sure that it is precisely centered and is without play with respect to the shaft end.

- Shafts shall be dynamically balanced in order to guarantee a small unbalance, according to the required speed of operation.
- Carbon brushes shall always be in full contact and shall not be shock or impact stressed.

Every error of mounting will reduce the useful life of the carbon brushes and the hard silver sliprings.

Rough dirt, dust, humidity, oil, solvents and their gases should be kept away so they can not reach the slipring or get into the case. They could influence the slipring transmission or e.g. reduce the resistance to ground of a connected measuring point.

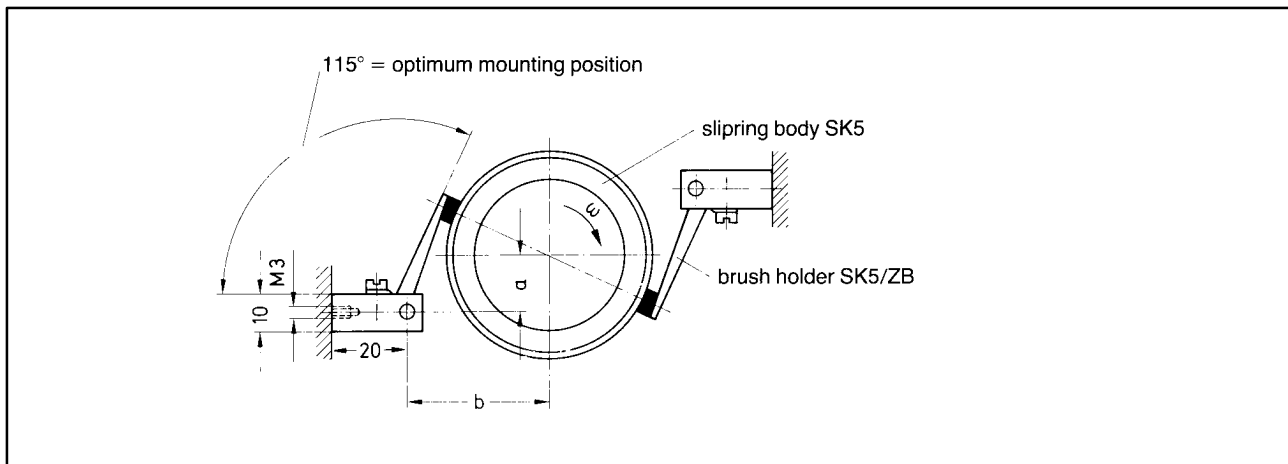

Fig. 10.1: Slipring body SK5 with brush holder SK5/ZB, mounting example

Type	Distance a in mm approx.	Distance b in mm approx.
SK5/40	16	38
SK5/50	13	43
SK5/55	12	45
SK5/80	6	59
SK5/95	2.5	66

11 Connection of measurement leads

Four leads each approx. 175 mm long are brought out from the slipring body SK5. Cable ends are tinned which facilitates to solder further connection cables. Depending on the application it is recommended to secure the measurement cables on the shaft by means of a cement or self adhesive tape.

Five screw connections are available on the brush holder for the connection of the stationary leads. These are associated with the colour code of the cores of the slipring body (see fig. 9.2).

11.1 Hints for measurements

In the case of strain gauge measurements the full bridge is recommended because the influence from the slipping transmission will have a much smaller effect than with half or quarter bridges. For high precision measurements the 700 Ω full bridge is preferred but also with 350 Ω or 120 Ω full, half, or quarter bridges the errors will be relatively small.

11.2 Mass or earth connection

On the slipping body SK5 the slipping with the slightly smaller diameter is connected to the mass of the slipping body thus enabling proper earthing of the rotor part. This slipping is associated with the yellow connection when mounting the brush holder.

If the operating voltage zero (\varnothing) of the amplifier shall also be connected to machine earth the cable screen shall be connected with the yellow connection of the brush holder. No other earth connection shall be made in order to avoid earth loops (see fig. 11. 1).

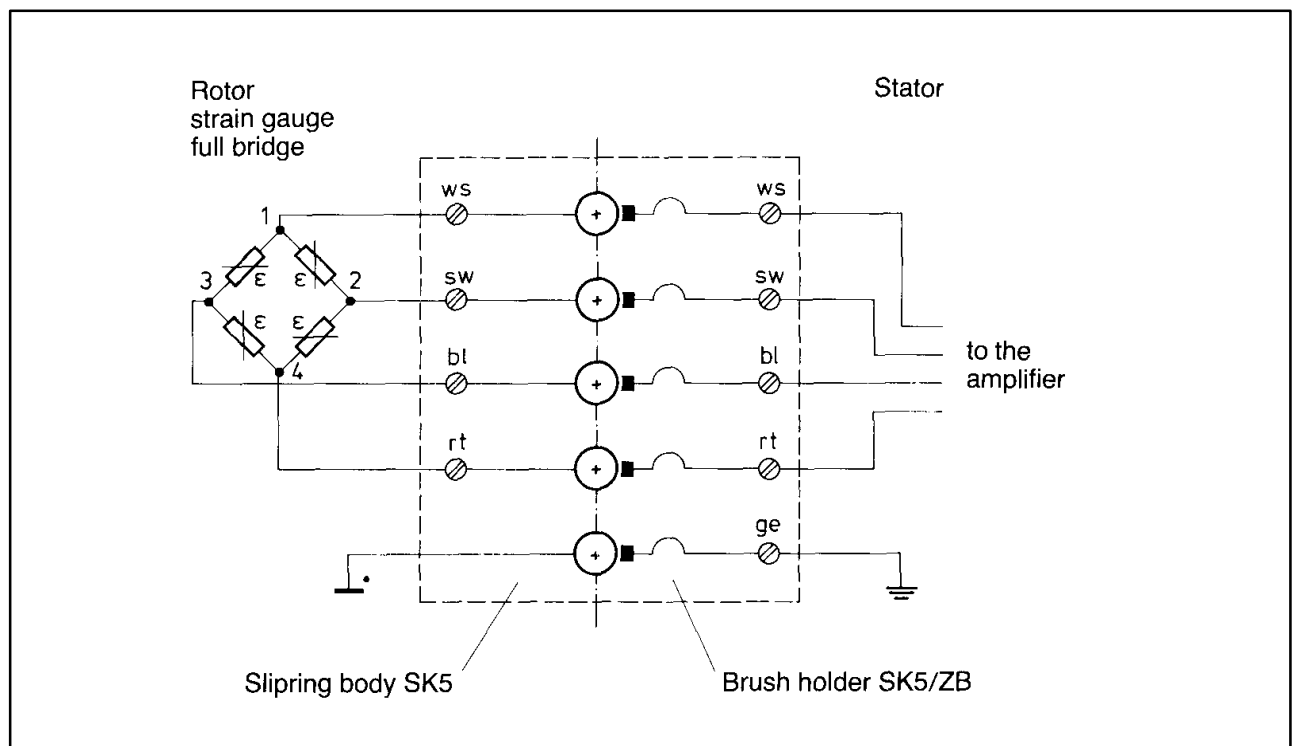

Fig. 11.1: Slipping assembly SK5, circuit diagram with earth connection

12 Maintenance

The slipring bodies SK5 with the brush holder are quite tough. Only the hard silver sliprings and the carbon brushes are subject to some wear which should be monitored. If service speeds are mostly below the maximum speed of rotation an average service life of $4 - 10^8$ revolutions can be achieved. Dirty sliprings should be carefully cleaned with a contact cleaning agent. If brushes are worn out one can either mount a new brush holder SK5/ZB or replace the carbon brushes (P/N 3-3098.0006). Brush holders SK5/ZB and the carbon brushes are the same for all SK5 versions.

13 Technical Data

13.1 Electrical values

Type		SK5
Number of sliprings		5
Resistance between slipring and brush	mΩ	< 40
Fluctuation of the resistance	mΩ	< 2
Termo-electric voltage measured between tow brushes when the sliprings are short-circuited (after runing until warm)	μV	< 10
Voltage limit	V	60
Current limit	A	2
Nominal temperature range	°C	- 10...+ 60
Service temperature range	°C	- 10...+ 90
Storage temperature range	°C	- 50...+ 90

13.2 Mechanical values

Mechanical shocktest Number of shocks Duration Acceleration	ms m/s ²	1000 3 150
Permissible vibration Frequency range Duration Acceleration	Hz h m/s ²	10..55 1.5 50
Permissible speed SK5/40, SK5/50, SK5/55 SK5/80, SK5/95	min ⁻¹ min ⁻¹	6000 4000

14 Dimensions

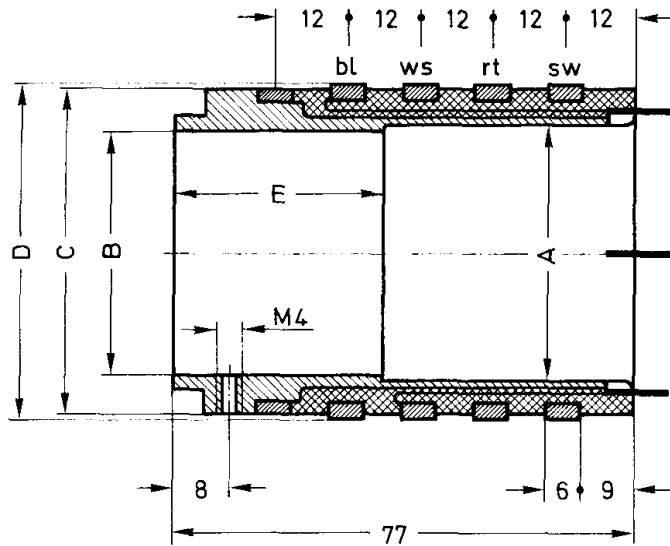

Type	Shaft \varnothing in mm	Dimensions in mm					Weight in kg
		$\varnothing A$	$\varnothing B$	$\varnothing C$	$\varnothing D$	E	
SK5/40	40 _{h6}	42 +0,2	40 ^{M6}	54	55	35	0.23
SK5/50	50 _{h6}	50.1 +0.2	50 ^{M6}	64	65	36	0.28
SK5/55	55 _{h6}	55.1 +0.2	55 ^{M6}	68	69	40	0.31
SK5/80	80 _{h6}	80.1 +0.2	80 ^{N6}	99	100	40	0.52
SK5/95	95 _{h6}	95.1 +0.2	95 ^{N6}	115	116	40	0.67

Fig. 14.1: Slipping body SK5

Moment of massinertia

Type	Moment of massinertia I_x (axial) in gm ²
SK5/40	0.235
SK5/50	0.446
SK5/55	0.517
SK5/80	2.221
SK5/95	3.712

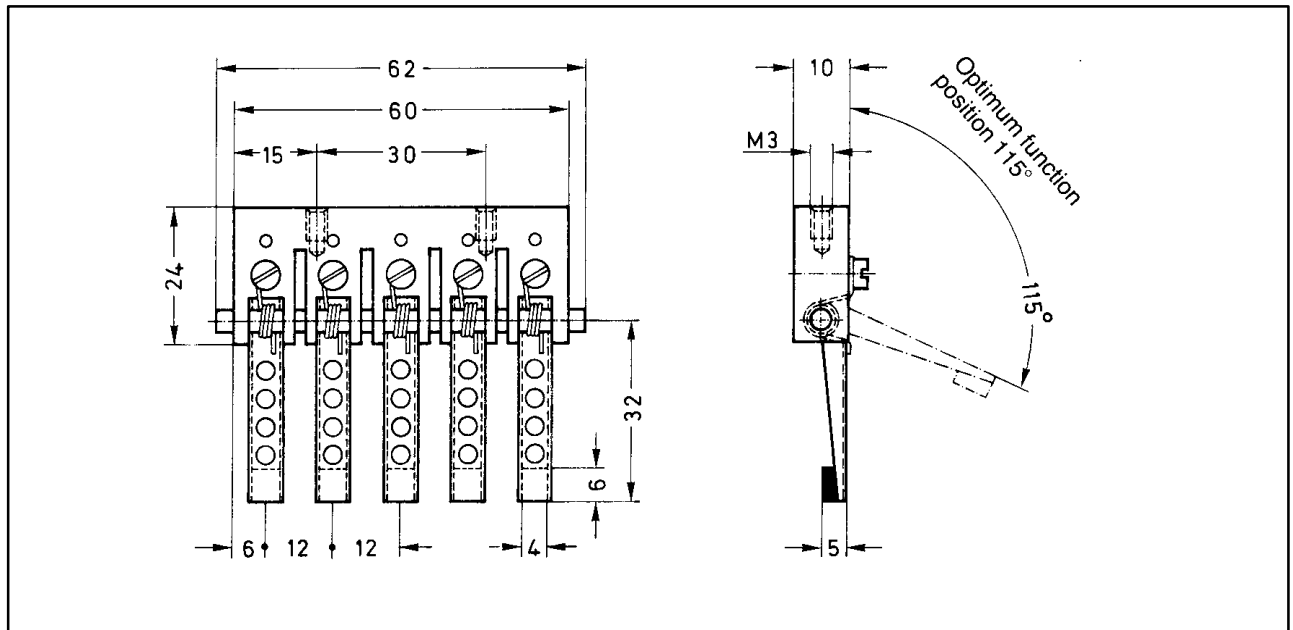

Fig. 14.2: Brush holder SK5/ZB

15 Scope of supply (SK5)

- 1 piece slipping body SK5
- 2 pieces brush holder SK5/ZB

Modifications reserved.

All details describe our products in general form only. They are not to be understood as express warranty and do not constitute any liability whatsoever.

Hottinger Baldwin Messtechnik GmbH

Postfach 10 01 51, D-64201 Darmstadt
Im Tiefen See 45, D-64293 Darmstadt
Tel.: +49/61 51/ 8 03-0; Fax: +49/61 51/ 8039100
E-mail: support@hbm.com www.hbm.com



measurement with confidence