

Mounting instructions

Pressure transmitter

P19

Contents	Page
Notes on safety	4
1 Scope of supply	7
2 Application	7
3 Mechanical construction	7
4 Electrical connection	8
4.1 Electrical connection of the pressure transmitter	8
4.2 Connection diagram, output 0...10V and 0...20mA	9
4.3 Connection diagram, output 4...20mA	9
5 Adjustment of the output signal	9
5.1 Adjustment of the output span	10
5.1.1 Coars adjustment (DIP switches S1...S4)	10
5.1.2 Fine adjustment of span	10
5.1.3 (Option) Span fine adjustment with calibration shunt (with no pressure applied)	11
5.1.3.1 Span as adjusted at the factory	11
5.1.3.2 Any full scale value in the range from 40%...160%	11
5.1.3.3 Adjustment of connection insrtuments with calibration shunt	12
5.2 Taring the initial pressure	12
6 Technical data (to DIN 16 086)	13
7 Dimensions	15
8 Copy of Declaration of Conformity	16

Safety instructions

Appropriate use

The P19 pressure transmitter is to be used exclusively for pressure measurement tasks and control operations which are directly connected with them. Any use which goes beyond this is considered to be improper.

To guarantee safe operation, this pressure gauge must only be used in accordance with the information provided in the Operating Instructions. In addition, the required legal and safety regulations for the specific operational conditions are to be taken into account during operation. Similarly, this is also valid for the utilization of accessories.

This pressure gauge is not intended to be a safety element even when used properly. Flawless and safe functioning of this pressure gauge requires appropriate transport, competent warehousing, assembly and mounting as well as careful operation and maintenance.

General hazards in the case of non-observance of the safety instructions

The P19 pressure transmitter for measuring gauge pressure is a reliable state of the art device. Residual hazards can result when untrained personnel install and operate this pressure gauge improperly.

Anyone who is charged with the assembly, initial operation, maintenance, or repair of this pressure gauge must have read and understood the Operating Instructions and in particular the technical safety information.

Residual hazards

The extent of performance and delivery of the pressure gauge only covers part of the scope of metrology. In addition, the technical safety consequences of measurement technique are to be planned for, realized and responsibly dealt with by plant designers/equippers/operators in such a way that residual hazards are minimized. Existing regulations are to be observed in each case. Attention is to be called to residual hazards which are connected with metrology.

In these instructions, the following symbols indicate residual hazards:



Symbol:  *Meaning:* Hazard for humans

This symbol indicates that failure to comply with the safety precautions can result in severe injury or death.



Symbol:  *Meaning:* Hazard for objects

This symbol indicates that failure to comply with the safety instructions can result in material damage (destruction to parts of the plant).

Information



Symbol:  *Meaning:* Information

This symbol indicates that a useful piece of additional information is given at this location.

Reconstruction and modifications

The pressure gauge may not be changed either in its construction or in a safetytechnical manner without our express authorization. Any modification excludes a liability on our part for any resulting damages.

In particular, any repairs, soldering on the printed circuit boards, and replacement of components are prohibited. Repairs may only be made by HBM.

Qualified personnel

This device is to be repaired exclusively by qualified personnel in accordance with the technical data, and in connection with the following safety regulations and provisions. In addition, the required legal and safety regulations for the specific operational conditions are to be taken into account during operation. Similarly, this is also valid for the utilization of accessories.

Qualified personnel are those who are familiar with the setup, mounting, initial operation, and operation of this product and who have the corresponding qualifications for their activities.

Prevention of accidents

Although the overload limit of the transducer many times exceeds the maximum measuring value, the relevant accident prevention regulations of the employers associations must be observed. For example, in circumstances where limits cannot be set satisfactorily, overload protection must be provided around the transducer.

1 Scope of supply

The standard version includes:

- 1 pressure transmitter P19
- 1 Bonded seal (USIT™), size U 8.5x5x13.4x1
- 1 Bonded seal (USIT™), size U 22.7x30x2
- 1 cable socket for DIN plug
- 1 P19 operating manual

2 Application

Pressure transmitters for gauge pressure or absolute pressure have been designed for measurement of static and dynamic pressures in liquids and gases.

3 Mechanical construction

Before mounting or dismantling the P19, make sure that there is no pressure on the line.

Use the the hexagon (a.f. 27) for mounting and dismantling.

P19 pressure transmitters in gauge pressure version are equipped with a ventilation bore on the pressure connection side of the housing. This bore should not be closed. The ventilation bore is protected by a stopper permeable to gas. The P19 complies with protection class IP65 to EN 60 529 and is therefore dustproof and hoseproof.

4 Electrical connection

4.1 Electrical connection of the pressure transmitter

Three-wire connection with 0...10V output (0...20mA, optionally)

Two-wire connection with 4...20mA, optionally

Electromagnetic compatibility (EMC)

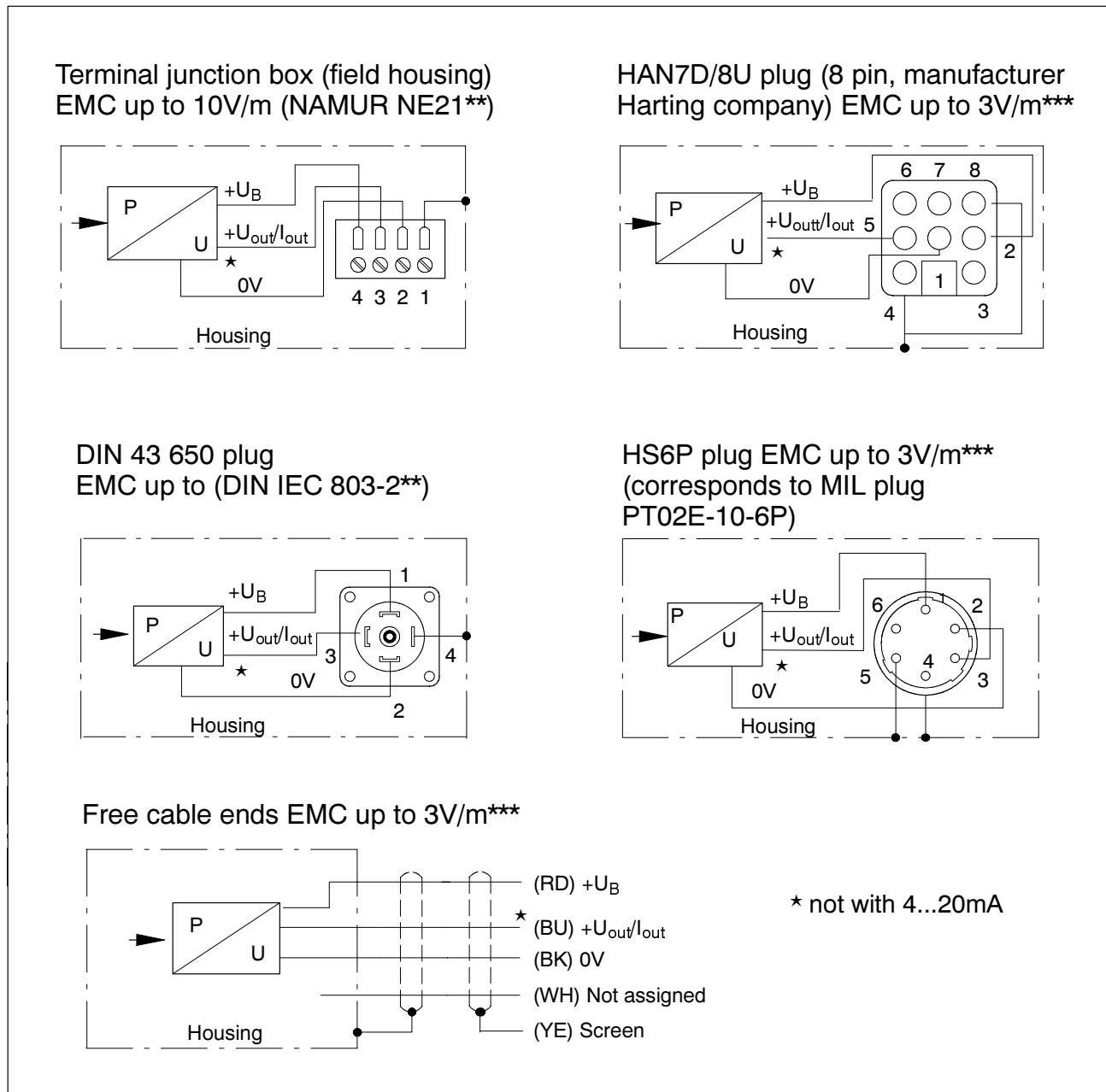

^{**} Also without screened cable

^{***} With double screened cable only

Screen must lay plane on the socket housing and the housing of the evaluation device.

Note: Reduced EMC when transmitter is opened, e.g. for adjustments.

4.2 Connection diagram, output 0...10V and 0...20mA

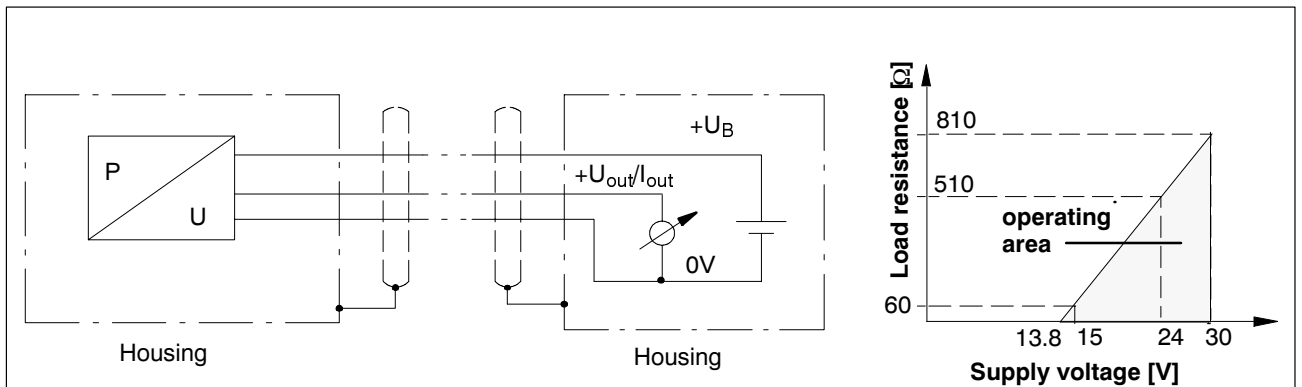

4.3 Connection diagram, output 4...20mA

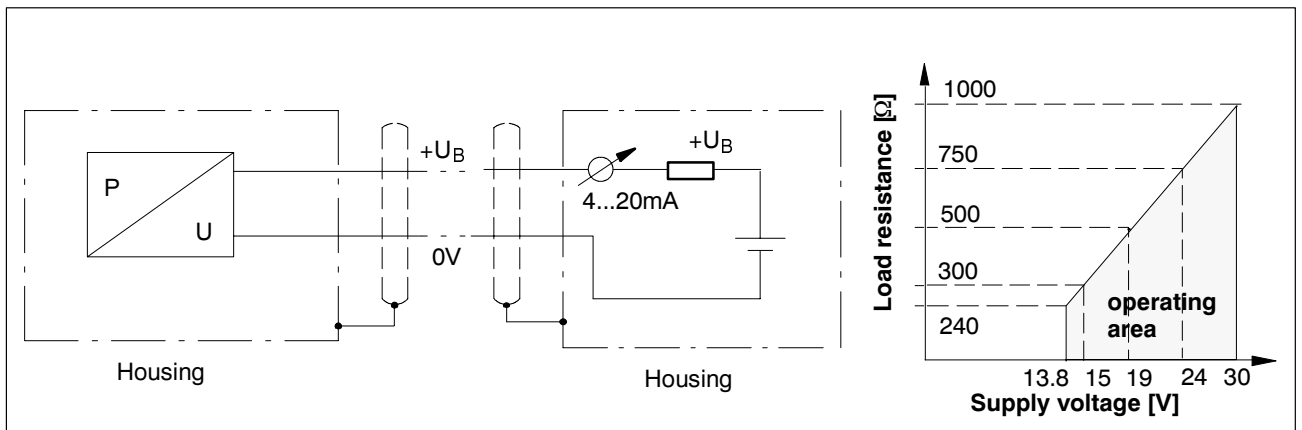

5 Adjustment of the output signal

The pressure transducer's zero signal and output span have already been adjusted at the factory. The values are given on the housing. You have the possibility to adjust the span (S) and zero signal (Z) to fit your individual requirements.

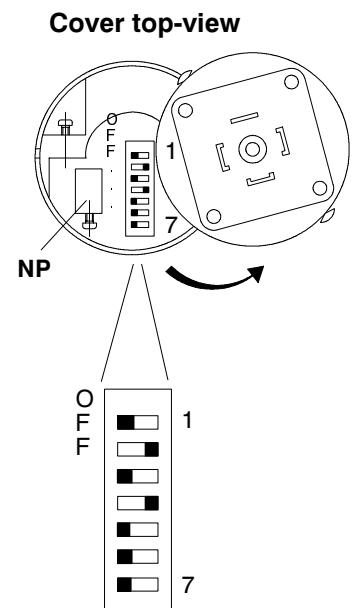
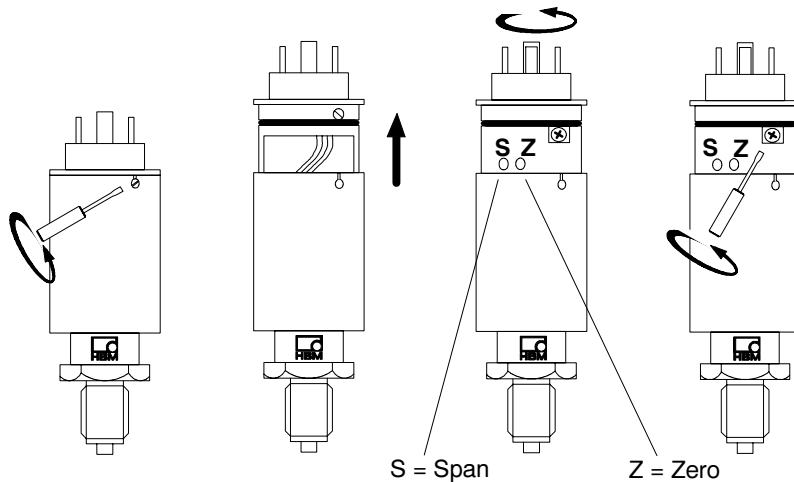

5.1 Adjustment of the output span

5.1.1 Coars adjustment (DIP switches S1...S4)

The measuring-span coarse adjustment depends on the transmitter's nominal measuring range (nom.=100%). The nominal measuring range is indicated on the housing.

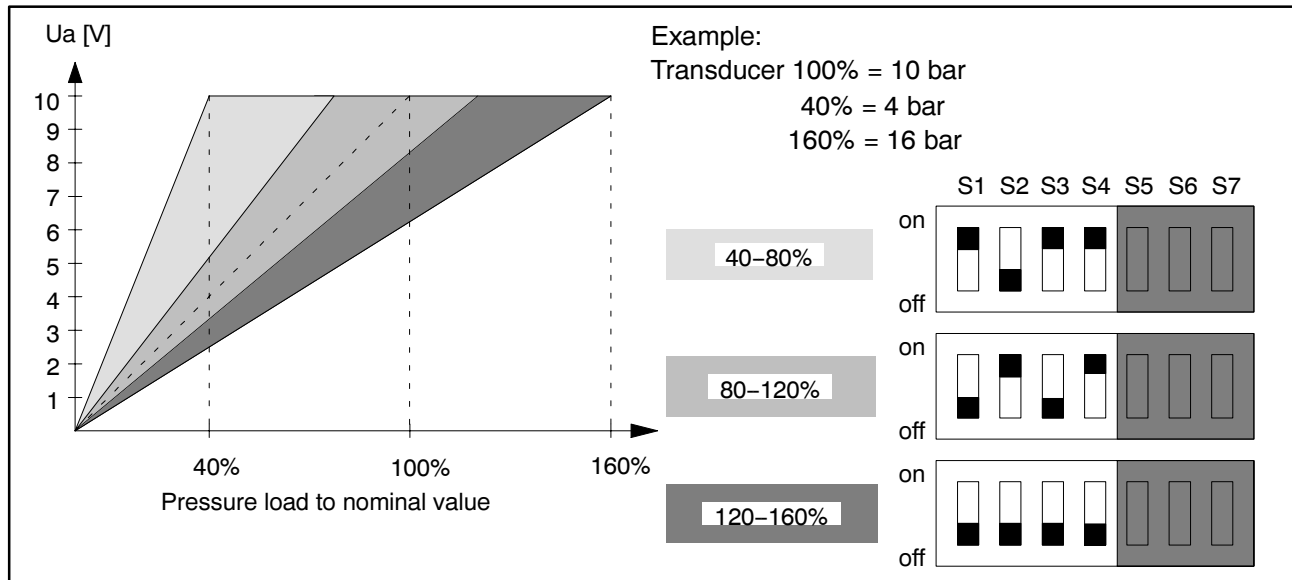

The zero point must be adjusted prior to span adjustment. Taring (switches 5, 6) and 7 must be set to "off".

Proceed as follows to correct the transmitter's zero point:

- Gauge pressure: pressure connection to ambient pressure
- Absolute pressure: pressure connection to vacuum
- Use potentiometer NP to adjust internal sensor zero-point in the range

20mV...100mV	at output 0...10V
0.04mA...0.2mA	at output 0...20mA
3.95mA...4.16mA	at output 4...20mA.

5.1.2 Fine adjustment of span

- Apply a pressure to the transmitter corresponding to the full-scale value.
- Use potentiometer "S" (SPAN) to adjust the desired span (e.g. 10V). With transmitters comprising the "calibration value" option, the full-scale value is adjustable without applying a pressure to the transmitter.

5.1.3 (Option) Span fine adjustment with calibration shunt (with no pressure applied)

5.1.3 .1 Span as adjusted at the factory

Span adjustment using the calibration shunt is only possible within the measuring range indicated on the housing.

- Do not change the coarse measuring-range.
- Set switches S5 and S6 to "off" position.
- Protocol the transmitter's zero-point.
- Set switch S7 to "on" position.
- Add calibration signal given on the housing of the transmitter to zero signal and adjust potentiometer "S" until the calculated value is achieved.
- Set switch S7 to "off" position

Example*: Full-scale pressure corresponds to nominal measuring range

Transmitter zero-point:	0.05V
+ specified calibration signal:	+ <u>3.47V</u>
full-scale pressure point to be adjusted:	3.52V

5.1.3 .2 Any full scale value in the range from 40%...160%

- Adjust coarse measuring-range and zero point as described in 5.1.1.
- Use equation below to determine the calibration signal to be adjusted.

$$\text{Output span to be adjusted} = \frac{\text{Calibrat. signal} \cdot \text{nom. meas. range}}{\text{Desired full-scale pressure}}$$

- Set switch S7 to "on" position.
- Add output span to current zero signal and use potentiometer "S" to adjust the output signal.
- Set switch S7 to "off" position.

Example*: Desired full-scale pressure of 5bar corresponds to 10V.

With a nominal measuring range of 10bar

$$\text{Output span to be adjusted} = \frac{3.47V \cdot 10bar}{5bar} = 6.98V$$

$$\text{Full-scale to be adjusted} = 0.05V + 6.98V = 7.03V$$

* Note: Please take into account, that the values for transmitters with current output must be changed with mA values.



5.1.3.3 Adjustment of connection instruments with calibration shunt

The stable and accurate calibration signal can even be used to adjust other connected instruments.

Example: Connection of a recorder writing width 10cm at an input voltage of 10V.

Adjustment: Calibration signal $3.47V \cong 3.47\text{cm}$ writing width.

5.2 Taring the initial pressure

Example:

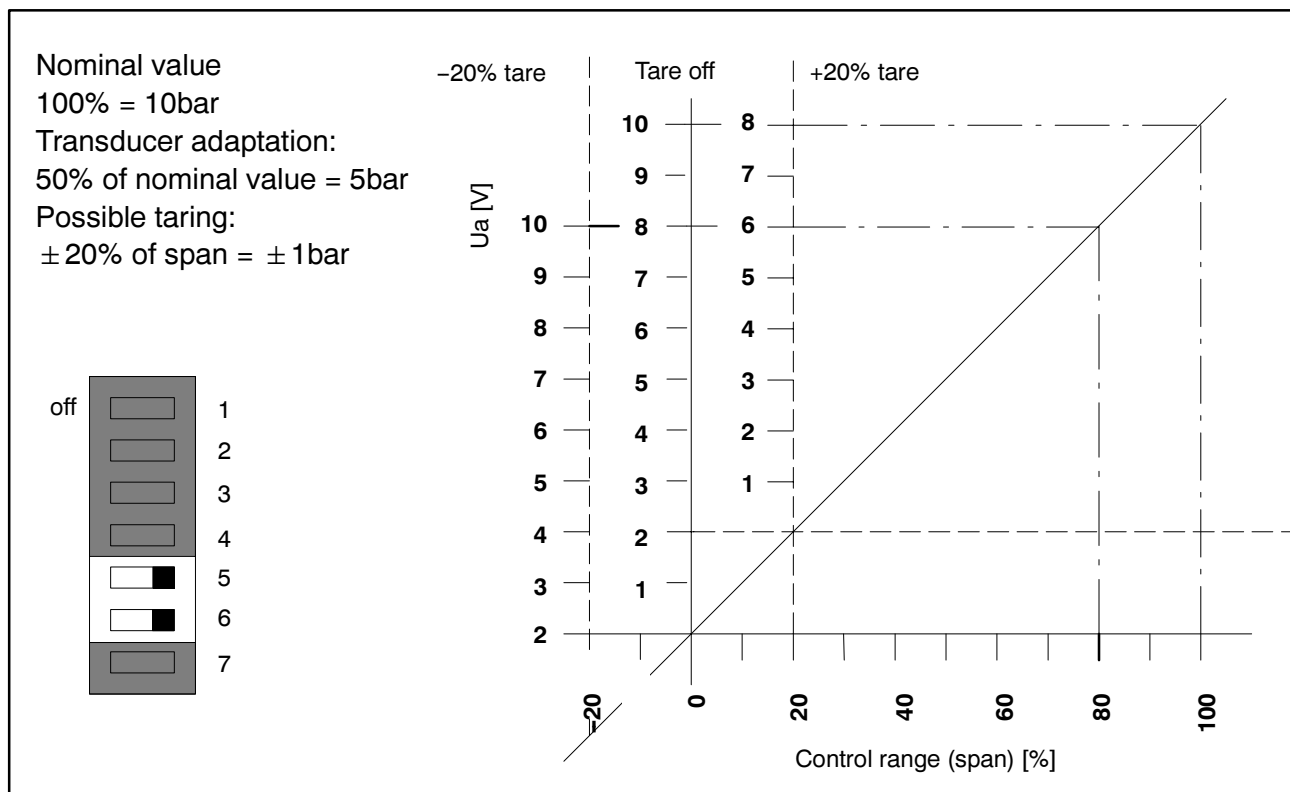

With the P19, the initial point can be shifted up to $\pm 20\%$ of the output span. For this, activate switches S5 and S6 (on) and use potentiometer "Z" (ZERO) to suppress the output signal resulting from the initial pressure except for a residual signal of approx. +30mV (or e.g. 0.06mA at output 0...20mA). Shifting the switches 5 and 6 to the "off" position deactivates the tare function.





6 Technical data (to DIN 16 086)

Type	P19						
Mechanical input characteristics							
For gauge pressure, measuring span span (1bar=14.5psi) Initial value	bar	10	20	50	100	200	500
		Ambient pressure					
For absolute pressure, measuring span Initial value	bar	10	20	50	Vacuum		
Resonant frequency of the diaphragm	kHz	12	16	23	45	65	85
Damping capacity of the diaphragm	1	<0.02					
Operating range at 23°C [73°F]	%	0...160					
Overload limit at 23°C [73°F]	%	200					
Test pressure	%	200					
Destruction range	%	>200					
With dynamic load							
admissible pressure	%	100					
admissible amplitude of vibration (to DIN 50 100)	%	100			70		
Material of the component parts in contact with the medium		1.4542 stainless steel [17-4 PH]					
Dead volume, without modular pressure port	mm ³ [cuin]	1000 [61.02]			1300 [79.33]		
Volume change	mm ³ [cuin]	1.5 [0.092]			1.0 [0.061]		
Output characteristics							
Span							
At voltage output 0...10V (standard)	V	10V±0.5% (max. output signal 11V)					
At current output 4...20mA (option)	mA	16mA±0.5% (max. output signal 22mA)					
At current output 0...20mA (option)	mA	20mA±0.5% (max. output signal 22mA)					
Output-signal adjustment range related to the nominal value, coarse adjustment in 3 steps	%	60; 100; 140					
Fine adjustment	%	±20					
Zero signal, factory setting	V	0.015...0.200					
Tare range, related to the output range, approx.	%	±20					
Limit load resistance, voltage output	Ω	> 900					
Load resistance, current output		please see diagram on page 5					

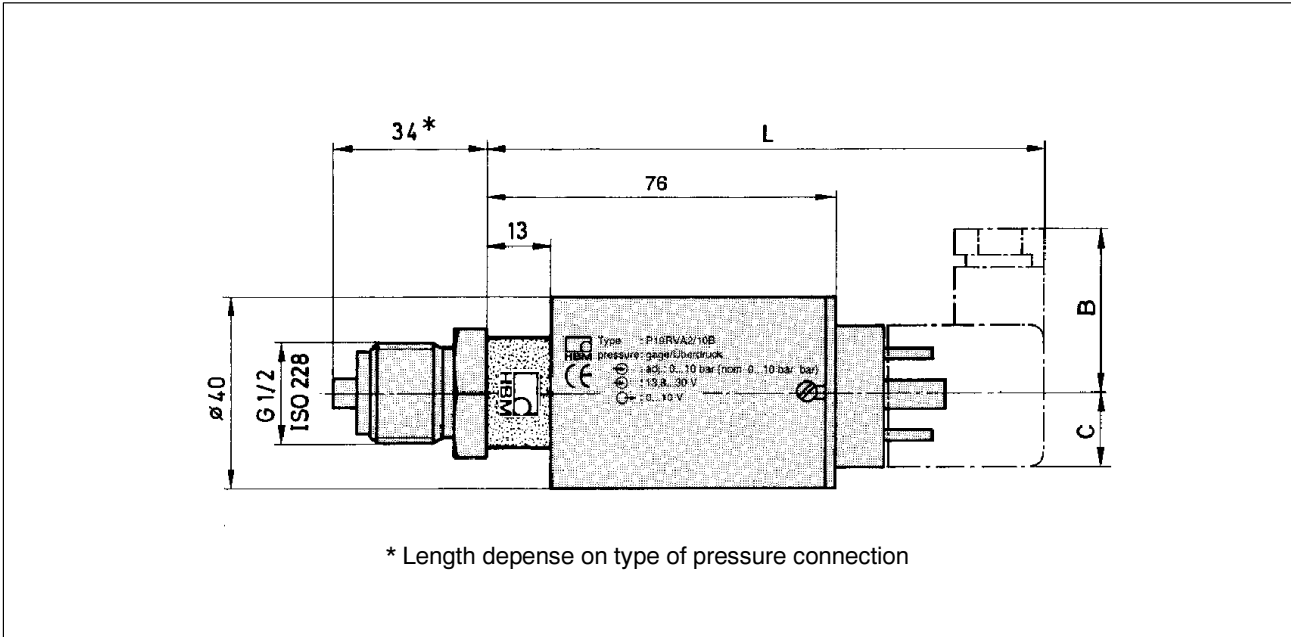
Temperature coefficient of the zero output per 10K [per 100F] in the nominal temperature range	%	< ±0.5; typ. < ±0.3 [$< \pm 1.9$; typ. < ±1.2]
Temperature coeff. of the span per 10K [per 100F] in the nominal temperature range	%	< ±0.3; typ. < ±0.2 [$< \pm 1.2$; typ. < ±0.8]
Non-conformity, zero-based	%	< ±0.5
Repeatability	%	< ±0.04
Max. meas. frequency with voltage output (-3dB)	kHz	2
with current output (-3dB)	kHz	1
Supply energy		
Supply voltage, nominal range	V	13.8...30
Maximum power consumption, voltage output (stand.)	mA	30
current output (Option)	mA	50
Ambient conditions		
Nominal temperature range	°C [°F]	-20...+70 [-5...160]
Service temperature range	°C [°F]	-25...+70 [-15...160]
Storage temperature range	°C [°F]	-40...+85 [-40...185]
Max. temperature of the medium (with horizontal installation or pointed downward, i.e. with cooling through ambient temperature < 60°C [140°F])	°C [°F]	105 [220]
Reference temperature	°C [°F]	23 [73]
Impact resistance (Type-tested to DIN IEC 68)		
Impact acceleration	m/s ² [g]	650 [65]
Type of protection to EN 50 529		
IP65		
Material, wetted parts		
Housing	stainless steel 1.4542 [17-4 PH] 1.4301, housing cover: AlMgCu ₂	
Mounting position		
any		
Weight, with DIN plug, approx.		
with terminal box	kg [oz]	0.25 [8.82]
	kg [oz]	0.43 [15.16]

7 Dimensions

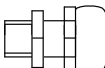

Electrical connection and dimensions									
Standard		L	B	C	Optional	L	B	C	
Plug DIN 43650		120	36	15	HAN 7D/8U plug (Harting company)		180	18	18
					Plug HS6P plug (corresp. to MILPT02E-6P)		135	11	11
					Pg gland (with 3m cable, free ends)		110	11	11
					Terminal box (field housing)		130	75	44



HOTTINGER BALDWIN MESSTECHNIK GMBH
Postfach 10 01 51, D-64201 Darmstadt
Im Tiefen See 45, D-64293 Darmstadt
Tel.: +49 / 61 51 / 8 03-0; Fax: +49 / 61 51 / 89 48 96
Internet: <http://www.hbm.de>

Modifications reserved.
All details describe our products in general form only. They are not to be understood as express warranty and do not constitute any liability whatsoever.