

T32FNA

Torque Transducers



Special features

- Torque measurement without effects from bearings
- Brushless transfer of measured signals
- Measurement of rapidly changing (dynamic) and constant torques
- Measurement with correct polarity of positive and negative torque
- Nominal speed from 11000 min⁻¹ up to 20000 min⁻¹
- Nominal torque from 50 N·m up to 25 kN·m
- Can handle power up to 28.8 MW (39000PS)

Type-Survey

Type (Ordering designation)	Nominal torque	Nominal speed
T32FNA/50Nm	50 N·m	20 000 min ⁻¹
T32FNA/100Nm	100 N·m	20 000 min ⁻¹
T32FNA/200Nm	200 N·m	20 000 min ⁻¹
T32FNA/500Nm	500 N·m	15 000 min ⁻¹
T32FNA/1kNm	1 kN·m	15 000 min ⁻¹
T32FNA/2kNm	2 kN·m	15 000 min ⁻¹
T32FNA/10kNm	10 kN·m	11 000 min ⁻¹
T32FNA/25kNm	25 kN·m	11 000 min ⁻¹

Dimensions (in mm; 1mm = 0.03937 inches)

T32FNA/50 N.m ... 25 kN.m

Plug for speed measuring signal and indication of direction

Plug for torque measuring signal

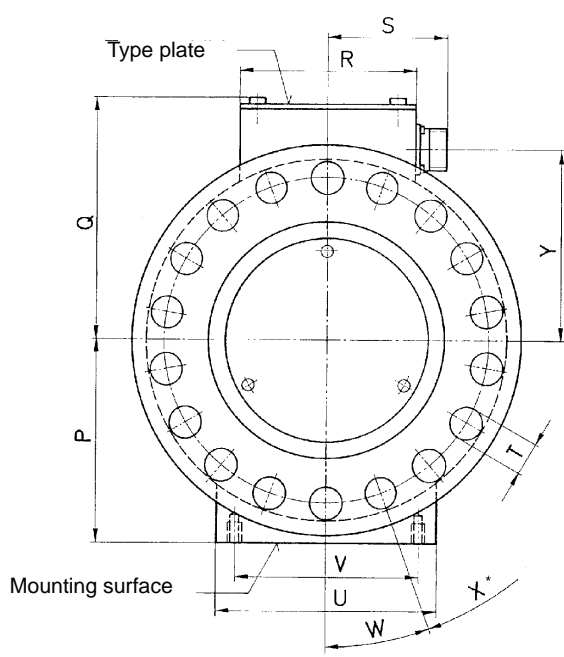
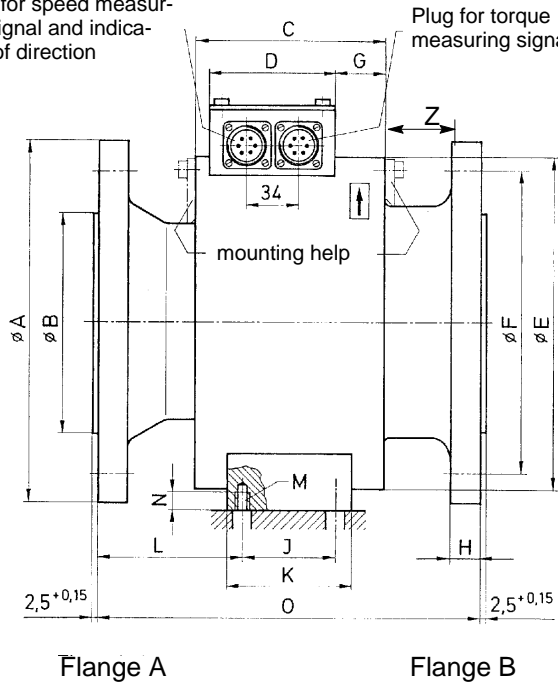

* Permissible deviation of pitch ±5'

Dimensions without tolerances to DIN 7168-m

T32FNA 50 N·m ... 200 N·m

A	B	C	D	E	F	G	H	J	K	L	M	N
90	60-0.005	84	70	107	72±0.1	6	8.5	15	38	76	M5	8
O	P	Q	R	S	T	U	V	W	X	Y	Z	
161.5-0.5	66.5-0.2	87.5	105	69	6.4 ^{H12}	70	30	45°	8x45°	58.8	28	

T32FNA 500 N·m ... 2 kN·m

A	B	C	D	E	F	G	H	J	K	L	M	N
157	100-0.005	102	80	124	130±0.1	17	13	22	38	90.5	M8	12
O	P	Q	R	S	T	U	V	W	X	Y	Z	
171.5-0.5	75-0.2	96	105	69	10.5 ^{H12}	70	54	24°	15x24°	67	17	

T32FNA 5 k·Nm ... 25 kN·m

A	B	C	D	E	F	G	H	J	K	L	M	N
235	140-0.005	122	80	216	196±0.1	33.5	18.5	60	80	90	M8	14
O	P	Q	R	S	T	U	V	W	X	Y	Z	
244.6-0.5	123-0.2	140.8	105	69	17 ^{H12}	130	110	20°	18x20°	113	42.6	

Specifications

Type		T32FNA							
Torque measuring system									
Nominal torque M_N	N·m	50	100	200	500	1 k	2 k	10 k	25 k
Nominal sensitivity (nominal signal range between torque = zero and nominal torque)	kHz	5							
Sensitivity tolerance (deviation of the actual frequency range from the nominal signal range at M_N)	%	< ±0.1							
Output frequency at torque = zero	kHz	10							
Nominal output frequency with positive M_N	kHz	15 (12 V peak-to-peak)							
with negative M_N	kHz	5 (12 V peak-to-peak)							
Load resistance	kΩ	≥2							
Temperature deviation per 10K at nominal temperature range of									
output signal (related to the actual value of signal span)	%	< ±0.1							
zero signal (related to the nominal sensitivity)	%	<±0.1				<±0.05			
Excitation voltage									
Square wave voltage (peak-to-peak)	V	54 ± 5 %							
Current consumption	mA	800 ± 5 %							
Release of calibration signal	V	80 ± 5 %							
Current consumption	mA	1000 ± 5 %							
Frequency	kHz	approx. 15							
Excitation voltage for the preamplifier	V	-15/0/+15							
Preamplifier, max. current consumption	mA	-20/0/+20							
Calibration signal , value given on name plate	–	approx. 50 % from M_N							
Tolerance of calibration signal , related to M_N	%	< ±0.05							
Linearity deviation including hysteresis , related to nominal sensitivity	%	< ±0.3		< ±0.2		< ±0.1			
Rel. standard deviation of the reproducibility accord. to DIN 1319, rel. to variation of the output signal	%	< ±0.03							
Speed measuring system									
Nominal speed	min ⁻¹	20000		15000		11000			
Output signal , pulse voltage (peak-to-peak)	V	25							
Load resistance	kΩ	≥5							
Minimum speed to achieve sufficient pulse quality	min ⁻¹	2							
General information on the torque transducers									
Protection class , according to EN 60529		IP 54							
Weight , Rotor	kg	2.5	7.1	7.2	7.3	31.6	32		
Stator	kg	2.8	3.0		11.0				
Nominal temperature range	°C [°F]	+10...+60 [+50...+140]							
Service temperature range	°C [°F]	-10...+60 [-15...+140]							
Storage temperature range	°C [°F]	-50...+70 [-60...+160]							
Additional reliability data									
Mechanical shock , degree of precision to DIN IEC 68, part 2-27; IEC 68-2-27-1987									
Number	n	1000							
Duration	ms	3							
Acceleration	m/s ²	500							
Vibration stress test , degree of precision to DIN IEC 68 part 2-6; IEC 68-2-6-1982									
Frequency range	Hz	5...65							
Duration	h	1.5							
Acceleration	m/s ²	50							

Specifications (continued)

Mechanical values									
Nominal torque M_N	Nm	50	100	200	500	1 k	2 k	10 k	25 k
Torsional stiffness C_T	kNm/rad	10.5	19.5	34.3	142	242	369	2910	6480
Torsion angle at M_N	grad	0.27	0.29	0.33	0.20	0.24	0.31	0.19	0.22
Mass moment of inertia	gm ²		1.85			16		149	154
Balance quality-level to DIN ISO 1940		G 2.5							
Max. limits for relative shaft vibration* (peak-to-peak)	μm	$s_{\text{max}} = \frac{4500}{\sqrt{n}}$							
Max. limits	mm	± 2.5							
Max.	mm	± 3							
Mechanical limit values**									
Limit torque, related to M_N	%	150							
Breaking torque, related to M_N	%	>300							
Lateral limit force on the rotor	N	50	100	190	410	1.1 k	1.6 k	5.7 k	14 k
Axial limit force on the rotor	kN	1.3	2.5	5	7	14	27	100	200
Bending limit moment on the rotor	Nm	6	12	23	60	115	230	1.15 k	2.8 k
Vibration amplitude to DIN 50 100 (peak-to-peak)	Nm	35	70	140	350	700	1.4 k	7 k	17.5 k

* s_{max} in the flange area of T30 FNA is defined in accordance with DIN 45 670 or VDI 2059

** Each type of irregular stress can only be permitted with its given limit value (bending moment, side load or axial load, exceeding the nominal speed) if none of the others can occur. Otherwise the limit values must be reduced. If for instance 30% of the bending moment and also 30% of the side load are present, only 40% of the axial load are permitted, provided that the nominal torque is not exceeded. With maximum additional loading, measuring errors of the order of 1% of the nominal torque can occur.

Accessories, to be ordered separately

Connecting cable	Length [m]	Lead connection
Kab 139A-6	6	Binder 423 - free ends (Greenline)
Cable extension		
Kab 0304A-10	10	7-pole socket - 7-pole plug (Greenline)
Kab 8/00-2/2/2	min. 10	Cut to length

Couplings

HBM offers Renck-curved-tooth couplings® for mounting.

Dimensions and specifications can be found in separate brochure which are available on request.

GLB up to 20 000min⁻¹ (depends on the nominal speed)

SBG up to 3 000min⁻¹

Also, couplings from Rexnord of Dortmund are matched to HBM torque transducers.

Modifications reserved.
All details describe our products in general form only. They are not to be understood as express warranty and do not constitute any liability whatsoever.

Hottinger Baldwin Messtechnik GmbH

Postfach 10 01 51, D-64201 Darmstadt
Im Tiefen See 45, D-64293 Darmstadt
Tel.: +49/61 51/ 8 03-0; Fax: +49/61 51/ 8039100
E-mail: support@hbm.com www.hbm.com



measurement with confidence