

T10F

Torque Flange



Special features

- Extremely short design
- High permissible dynamic loads
- High permissible transverse forces and bending moments
- Very high torsional stiffness
- Contactless
- Selectable calibration signal
- Integral speed measurement (option)

Installation example

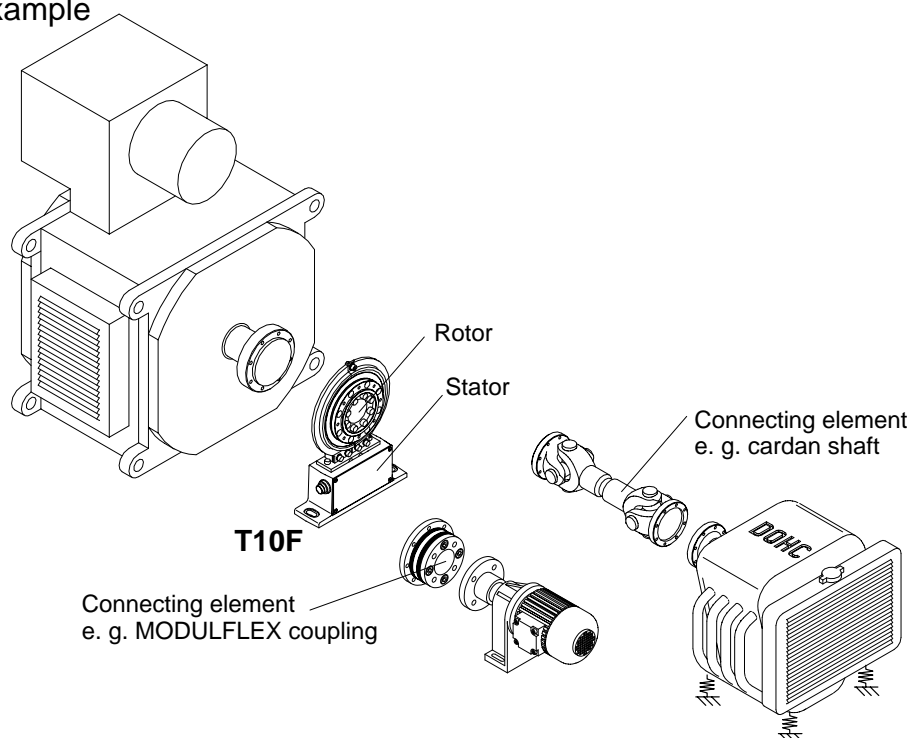

Specifications

Type	T10F									
Accuracy class	0.1									
Torque measuring system										
Nominal torque M_{nom}	N-m	50	100	200	500	1k	2k	3k	5k	10k
Nominal sensitivity (nominal signal range between torque = zero and nominal torque)										
Frequency output	kHz	5								
Voltage output	V	10								
Characteristic tolerance (deviation of the actual output quantity at M_{nom} from the nominal signal range)										
Frequency output	%	± 0.1								
Voltage output	%	± 0.2								
Output signal at torque = zero										
Frequency output	kHz	10								
Voltage output	V	0								
Nominal output signal										
Frequency output										
with positive nominal torque	kHz	15 (5V symmetric ¹)/12V asymmetric ²)								
with negative nominal torque	kHz	5 (5V symmetric ¹)/12V asymmetric ²)								
Voltage output										
with positive nominal torque	V	+10								
with negative nominal torque	V	-10								
Load resistance										
Frequency output	kΩ	≥ 2								
Voltage output	kΩ	≥ 5								
Long-term drift over 48h										
Voltage output	mV	≤ ± 3								
Measurement frequency range										
Voltage output	Hz	0 ... 1000 (-3dB)								
Group delay time										
Frequency output	ms	0.15								
Voltage output	ms	0.9								
Residual ripple Voltage output	%	0.4 (peak-to-peak)								
Temperature influence per 10 K in the nominal temperature range										
on the output signal, related to the actual value of signal span										
Frequency output	%	< ± 0.1								
Voltage output	%	< ± 0.2								
on the zero signal, related to the nom. sensitivity										
Frequency output	%	< ± 0.1								< ± 0.05
Voltage output	%	< ± 0.2								< ± 0.15
Power supply (version KF1)										
Excitation voltage (square wave)	V	54 ± 5% (peak-to-peak)								
Release of calibration signal	V	80 ± 5%								
Frequency	kHz	approx. 14								
Max. current consumption	A	1 (peak-to-peak)								
Pre-amplifier excitation voltage	V	0/0/+15								
Pre-amplifier, max. current consumption	mA	0/0/+25								
Power supply (version SF1/SU2)										
Nominal supply voltage (protective low voltage)	V (DC)	18 ... 30; asymmetric								
Current consumption in measuring mode	A	< 0.9								
Current consumption in start-up mode	A	< 2								
Nominal power consumption	W	< 12								
Linearity deviation including hysteresis, related to the nominal sensitivity										
Frequency output	%	< ± 0.1 (< ± 0.05 optional)								
Voltage output	%	< ± 0.1 (< ± 0.07 optional)								

1.) RS 422 complementary signals; factory settings version SF1/SU2

2.) Factory settings version KF1 (no switching possible)

Nominal torque M_{nom}	N·m	50	100	200	500	1k	2k	3k	5k	10k	
Rel. standard deviation of the repeatability according to DIN 1319, by reference to variation of the output signal	%	< ± 0.03									
Calibration signal		approx. 50% of M_{nom} ; value given to the identification plate									
Tolerance of calibration signal	%	< ± 0.05									
Speed measuring system											
Measuring system		optical, by means of infrared light and metallic slotted disc									
Mechanical increments	Number	360				720					
Positional tolerance of the increments	mm	± 0.05									
Tolerance of the slot width	mm	± 0.05									
Pulses per rotation adjustable	Number	360; 180; 90; 60; 30; 15				720; 360; 180; 90; 60; 30; 15					
Output signal	V	5 symmetric (RS 422 complementary signals) 2 square wave signals 90° phase shifted									
Load resistance	kΩ	≥ 2									
Minimum speed for sufficient pulse stability	rpm	2									
Group delay time	μs	< 5 typ. 2.2									
Max. permissible axial displacement between rotor and stator	mm	± 2									
Max. permissible radial displacement between rotor and stator	mm	± 1									
Hysteresis of reversing the direction of rotation ^{3.)} with relative vibrations between rotor and stator											
Torsional rotor vibrations	Degree	< approx. 2									
Radial stator vibrations	mm	< approx. 2									
Permitted degree of soiling , in the optical path of the sensor fork (lenses, slotted disc)	%	< 50									
Protection against scattered light		by fork and infrared filter									
General data											
EMC											
EMI (Immunity) (EN50082-2)											
RF enclosure	V/m	10									
RF common mode	V _{PP}	10									
Magnetic field	A/m	100									
Burst	kV	2/1									
ESD	kV	4/8									
EME (Emission) (EN55011; EN55022; EN55014)											
RFI voltage		Class A									
RFI power		Class B									
RFI field strength		Class B									
Degree of protection according to EN 60529		IP 54									
Weight , approx. Rotor		0.9	0.9	1.8	3.5	3.5	5.8	7.8	14.0	15.2	
Rotor with speed measuring system		1.1	1.1	1.8	3.5	3.5	5.9	7.9	14.1	15.3	
Stator		1.1	1.1	1.2	1.2	1.2	1.3	1.3	1.4	1.4	
Reference temperature	°C [°F]	+23 [73.4]									
Nominal temperature range	°C [°F]	+10...+60 [+50...+140]									
Service temperature range	°C [°F]	-10...+60 [+14...+140]									
Storage temperature range	°C [°F]	-20...+70 [-4...+158]									
Impact resistance, test severity level to IEC 68; part 2-27; IEC 68-2-27-1987											
Number of impacts	n	1000									
Duration	ms	3									
Acceleration (half-sine)	m/s ²	650									
Vibration resistance, test severity level to IEC 68, part 2-6; IEC 68-2-6-1982											
Frequency range	Hz	5...65									
Duration	h	1.5									
Acceleration (amplitude)	m/s ²	50									

^{3.)} Can be switched off

Specifications (Continued)

Nominal torque M_{nom}	N·m	50	100	200	500	1k	2k	3k	5k	10k
Nominal speed (x1000)	rpm	15	15	15	12	12	10	10	8	8
Load limits^{4.)}										
Limit torque, related to M_{nom}	%	400				200				160
Breaking torque, related to M_{nom}	%	>800				>400				>300
Axial limit force	kN	2	2	4	7	7	12	14	22	31
Lateral limit force	kN	1	1	3	6	8	15	18	30	40
Bending limit moment	N·m	70	70	140	500	500	1000	1600	2500	4000
Oscillation bandwidth according to DIN 50100 (peak-to-peak)^{5.)}	kN·m	0.16	0.16	0.32	0.8	1.6	3.2	4.8	8.0	12.0
Mechanical values										
Torsional stiffness C_T	kN·m/rad	160	160	430	1000	1800	3300	5100	9900	15000
Torsion angle at M_{nom}	Degree	0.018	0.036	0.027	0.028	0.032	0.034	0.034	0.029	0.038
Maximum excursion at axial limit force	mm	< 0.03								
Additional max. concentricity error at lateral limit force	mm	< 0.01			< 0.02			< 0.03		
Additional plane-parallel deviation at bending limit moment	mm	< 0.2								
Balance quality-level to DIN ISO 1940		G 6.3								
Max. limits for relative shaft vibration (peak-to-peak)^{6.)}	µm	$s_{max} = \frac{4500}{\sqrt{n}}$								
Mass moment of inertia of the rotor										
I_y (about axis of rotation) $\times 10^{-3}$	kg·m ²	1.3	3.4	13.2	29.6	41	110	120		
I_y with speed system $\times 10^{-3}$	kg·m ²	1.7	3.5	13.2	29.6	41	110	120		
Proportional mass moment of inertia (measuring-body side)	%	51	44	39	38	33	31	33		
Proportional mass moment of inertia with speed measuring system (measuring-body side)	%	40	43	39	38	33	31	33		
Max. permissible static eccentricity of the rotor (radially)^{7.)}	mm	± 2								
Permissible axial displacement between shaft and housing^{7.)}	mm	± 2			± 3					

4.) Each type of irregular stress (bending moment, lateral or axial load, exceeding the nominal torque) can only be permitted with its given static load limit if none of the others can occur. Otherwise the limit values must be reduced. If for instance 30 % of the bending limit moment and also 30 % of the lateral limit force are present, only 40 % of the axial limit force are permitted, provided that the nominal torque is not exceeded. With the permitted bending moments, axial and lateral limit forces, measuring errors of about 1 % of the nominal torque can occur.

5.) With T10F/50 N·m the nominal torque may be exceeded by 100 %, with T10F/100 N·m up to 10 kN·m the nominal torque may not be exceeded.

6.) Relative undulations within the range of the adapter flange in accordance with DIN 45670/VDI 2059.

7.) See restricted values with speed measuring system.

T10F version	KF1	SF1	SU2
Measuring quantity			
Torque	■	■	■
Speed (option)		■	■
Power supply			
Excitation voltage 54 V _{pp} /14 kHz, square wave	■		
Supply voltage 18 V...30 V DC		■	■
Output signal			
10 kHz \pm 5 kHz	■	■	■
\pm 10 V			■
Connecting cable			
Torque	V1, V2, V3, V4	V5, V6	V5, V6
Speed		W1, W2	W1, W2

Rotor dimensions (in mm; 1 mm=0.03937 inches)

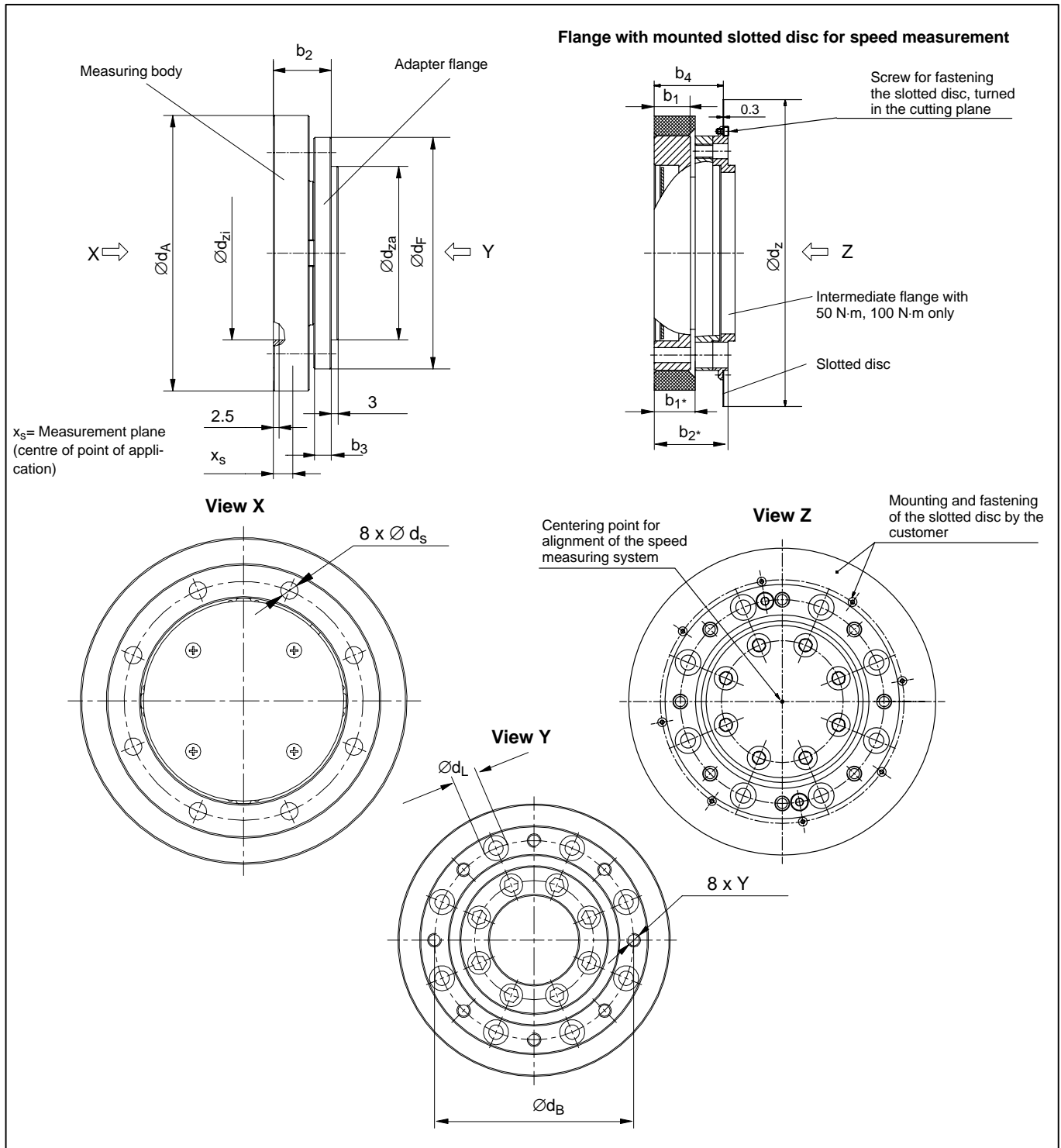

Nominal torque	Dimensions in mm															
	b_1	b_1^*	b_2	b_2^*	b_3	b_4	$\varnothing d_A$	$\varnothing d_B$	$\varnothing d_F$	$\varnothing d_L$	$\varnothing d_z$	$\varnothing d_{za\ g6}$	$\varnothing d_{zi\ H7}$	$\varnothing d_s$	Y	X_s
50 N-m	15.5	17.5	25	31.5	7.5	29.5	117	87	100	11	131	75	75	6.4	M6	13
100 N-m																
200 N-m	17.5	17.5	30.5	30.5	11	29.5	137	105	121	14	151	90	90	8.4	M8	14
500 N-m	20.5	20.5	40.5	40.5	18	33	173	133	156	20	187	110	110	13	M12	15.5
1 kN-m																
2 kN-m	22.5	22.5	42.5	42.5	18	35	207	165	191	24	221	140	140	15	M14	16.5
3 kN-m	27.0		55	55	26	35										18.8
5 kN-m	28.5	28.5	64	64	33.5	41	254	206	238	30	269	174	174	19	M18	19.5
10 kN-m	33.5		69	69												22.5

Stator B dimensions (in mm; 1 mm=0.03937 inches)

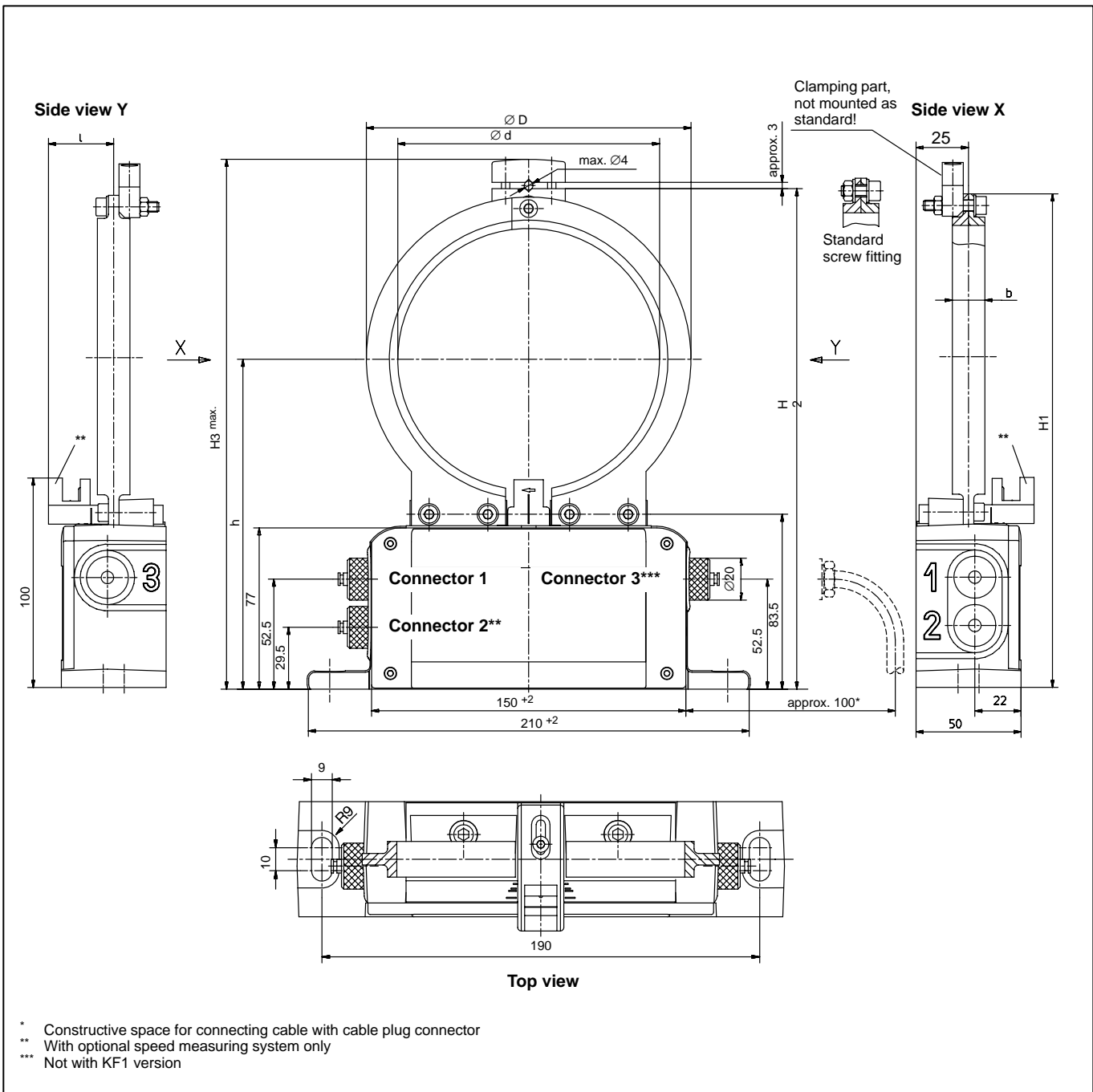

Nominal torque	Dimensions in mm							
	b	Ød	ØD	H1	H2	H3	h	l
50 N·m	17.5	125	155	235	239	253	157.5	31.5
100 N·m								
200 N·m	17.5	145	175	255	259	273	167.5	31.5
500 N·m	20.5	181	211	291	295	309	185.5	33.5
1 kN·m								
2 kN·m	22.5	215	245	325	329	343	202.5	34.5
3 kN·m								
5 kN·m	28.5	262	292	373	377	391	226.5	37.5
10 kN·m								

Specifications (Continued)

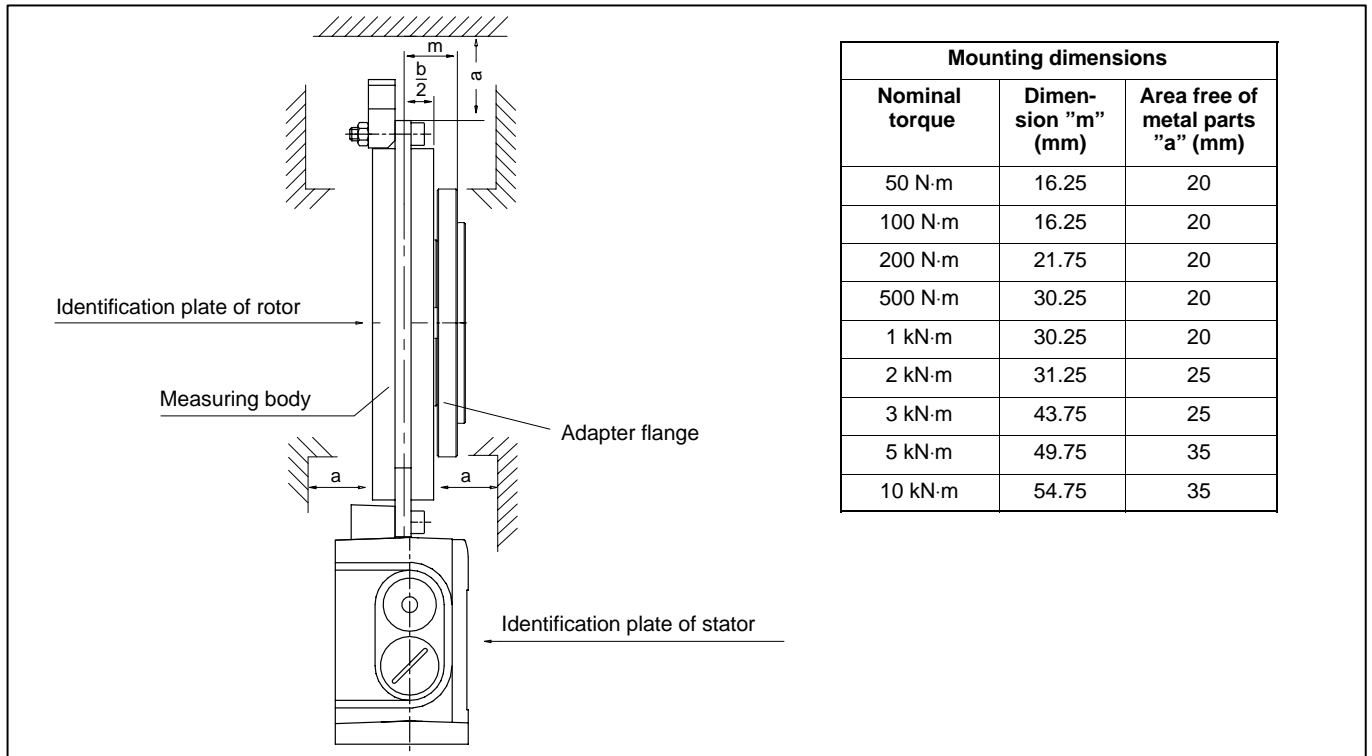

Screw fitting of the rotor

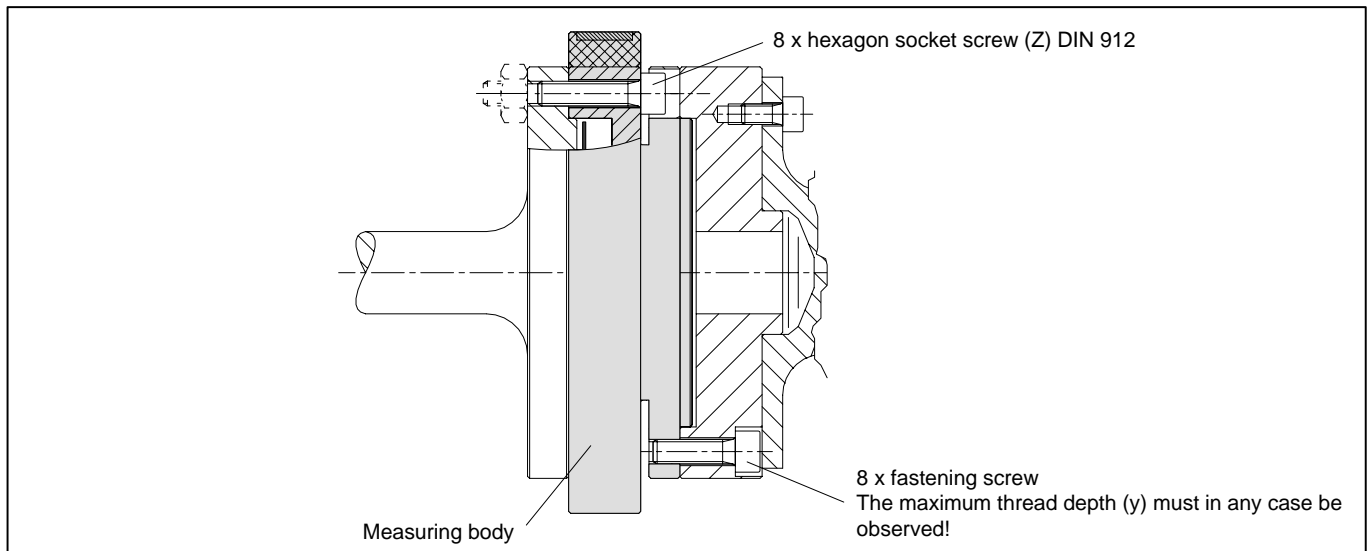

Nominal torque (N·m)	Fastening screws (Z)	Fastening screws class	Max. thread depth (y) in adapter flange (mm)	Prescribed fastening torque (N·m)
50	M6	10.9	7.5 ¹⁾	14
100				
200	M8		11	34
500	M12		18	115
1k	M12		18	115
2k	M14		18	185
3k	M14		26	185
5k	M18		33.5	400
10k	M18	12.9	33.5	470

¹⁾ With optional speed module 14mm; due to intermediate flange 6mm longer screws must be used.

Ordering number

Code	Option 1: Measuring range
050Q	50 N·m
100Q	100 N·m
200Q	200 N·m
500Q	500 N·m
001R	1 kN·m
002R	2 kN·m
003R	3 kN·m
005R	5 kN·m
010R	10 kN·m

Code	Option 4: Speed measuring system ²⁾
0	Without speed measuring system
1	360 pulses/revolution
2	180 pulses/revolution
3	90 pulses/revolution
4	60 pulses/revolution
5	30 pulses/revolution
6	15 pulses/revolution
7	720 pulses/revolution ³⁾

Code	Option 2: Electrical configuration
KF1	Output signal 10 kHz ± 5 kHz, Excitation voltage 14 kHz / 54 V; square wave
SF1	Output signal 10 kHz ± 5 kHz, Supply voltage 18...30 V DC
SU2	Output signal 10 kHz ± 5 kHz and ± 10 V, Supply voltage 18...30 V DC

Code	Option 3: Linearity deviation Hysteresis included
S	< ±0.1
G	< ±0.05 ¹⁾

Code	Option 5: Connecting cable
V0	Without connecting cable
V1	Torque connecting cable for KF1, 423-free ends, 6 m
V2 ²⁾	Torque connecting cable for KF1, 423-free ends, max. 80 m
V3	Torque connecting cable for KF1, 423-MS3106PEMV, 6 m
V4 ²⁾	Torque connecting cable for KF1, 423-MS3106PEMV, max. 80 m
V5	Torque connecting cable for SF1/SU2, 423-D-Sub 15P, 6 m
V6 ²⁾	Torque connecting cable for SF1/SU2, 423-D-Sub 15P, max. 50 m
W1	One torque and speed cable each, 423-D-Sub 15P, 6 m
W2 ²⁾	One torque and speed cable each, 423-D-Sub 15P, max. 50 m

Code	Option 6: Mounted MODULFLEX [®] couplings ⁴⁾
N	Without coupling
Y	With coupling

- 1) When voltage output < ±0.07
 2) Only option 2, Code SF1, SU2
 3) Only option 1, Code 002R, 003R, 005R, 010R
 4) Specifications see data sheet D23.T10FBS.D.x

Order no.: K-T10F - [] [] [] [] - [] [] [] [] - [] [] [] [] - [] [] [] [] [] [] [] [] [] [] m*)

Ordering example:

K-T10F - 5 0 0 Q - S F 1 - S - 0 - V 5 - Y [] [] [] [] [] [] [] [] [] [] m*)

*) With V2, V4, V6 and W2 selected, please specify desired cable length.

Accessories, to be ordered separately:

423G-7S cable socket, 7-pole, straight cable entry, for torque output (connector 1, 3), order no. 3-3101.0247

423W-7S cable socket, 7-pole, 90° cable entry, for torque output (connector 1, 3), order no. 3-3312.0281

423G-8S cable socket, 8-pole, straight cable entry, for speed output (connector 2), order no. 3-3312.0120

423W-8S cable socket, 8-pole, 90° cable entry, for speed output (connector 2), order no. 3-3312.0282

Raw cable Kab8/00-2/2/2, order no. 4-3301.0071

Modifications reserved.
 All details describe our products in general form only. They are not to be understood as express warranty and do not constitute any liability whatsoever.

Hottinger Baldwin Messtechnik GmbH

Postfach 10 01 51, D-64201 Darmstadt
 Im Tiefen See 45, D-64293 Darmstadt
 Tel.: +49/61 51/ 8 03-0; Fax: +49/61 51/ 8039100
 E-mail: support@hbm.com www.hbm.com



measurement with confidence